

# Suspended Scales

Mechanical



- ◆ Robust
- ◆ Accurate
- ◆ Reliable
- ◆ Portable
- ◆ Dual Markings Available for Metric and Avoirdupois
- ◆ Low Cost
- ◆ Easy to Read
- ◆ Corrosion Resistant
- ◆ Capacities- 11 lbs (5 kg) to 660 lbs (300 kg)

VALUE IN  
WEIGHING



# Suspended Scales

## Model 235 6S

Compact, robust and corrosion resistant, housed in a tough ABS plastic case with shatterproof polycarbonate dial cover. Low friction acetal bearings provide positive movement to give maximum sensitivity. Accurate to one part in 250 with up to 15% zero adjust. Supplied with top and bottom hooks.

### Option

- Round pan
- Galvanized scoop

### Dual Marked

- 5 kg x 20 g / 11 lb x 1 oz
- 10 kg x 50 g / 22 lb x 2 oz
- 25 kg x 100 g / 56 lb x 4 oz
- 50 kg x 200 g / 110 lb x 8 oz
- 100 kg x 500 g / 220 lb x 1 lb

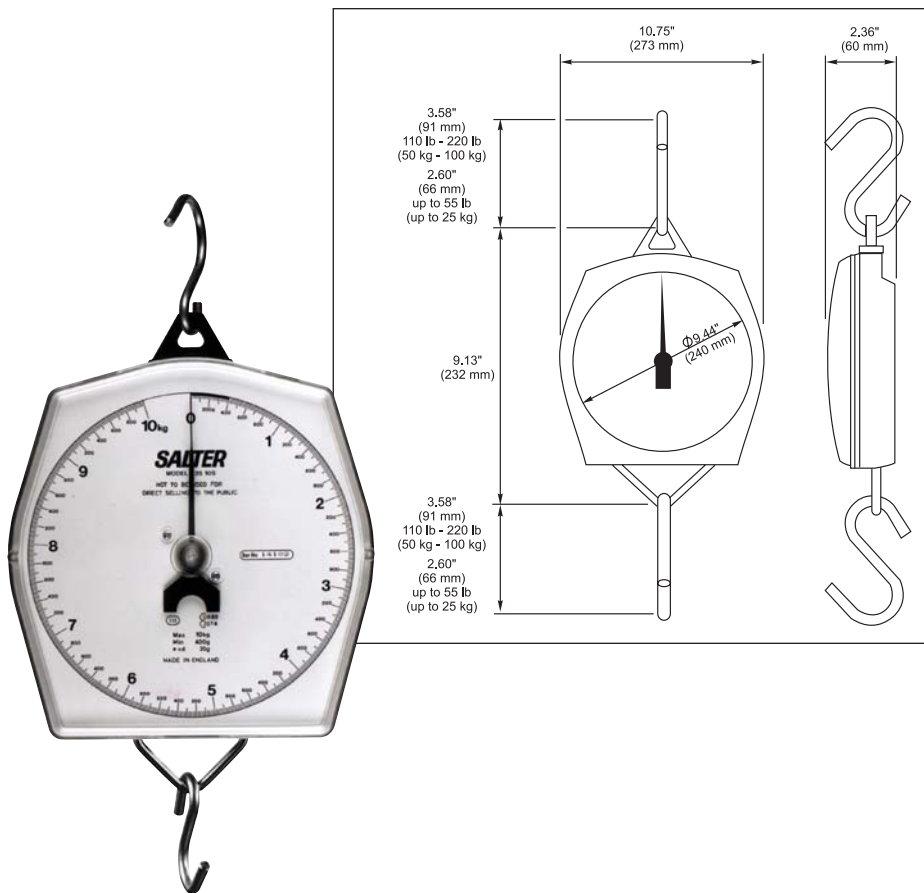
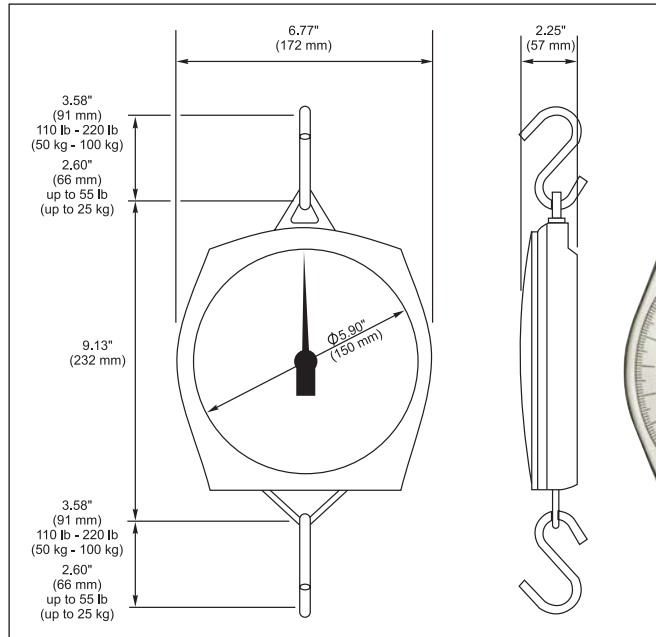

## Model 235 10S

Robust and corrosion resistant, housed in a tough ABS plastic case with shatterproof polycarbonate dial cover. Low friction bearings provide positive movement to give maximum sensitivity. Accurate to one part in 500 with up to 15% zero adjust. Supplied with top and bottom hooks.

### Option

- Round pan
- Galvanized scoop

### Dual Marked

- 5 kg x 10 g / 11 lb x 1/2 oz
- 10 kg x 20 g / 22 lb x 1 oz
- 25 kg x 50 g / 56 lb x 2 oz
- 50 kg x 100 g / 110 lb x 4 oz
- 100 kg x 200 g / 220 lb x 8 oz

**Model 235 6M**

*Compact, robust, housed in the traditional metal case. Accurate to one part in 250 with up to 15% zero adjustment. Supplied with top and bottom hooks.*

**Option**

*Round pan  
Galvanized scoop*

**Dual Marked**

- 5 kg x 20 g / 11 lb x 1 oz
- 10 kg x 50 g / 22 lb x 2 oz
- 25 kg x 100 g / 56 lb x 4 oz
- 50 kg x 200 g / 110 lb x 8 oz
- 100 kg x 500 g / 220 lb x 1 lb

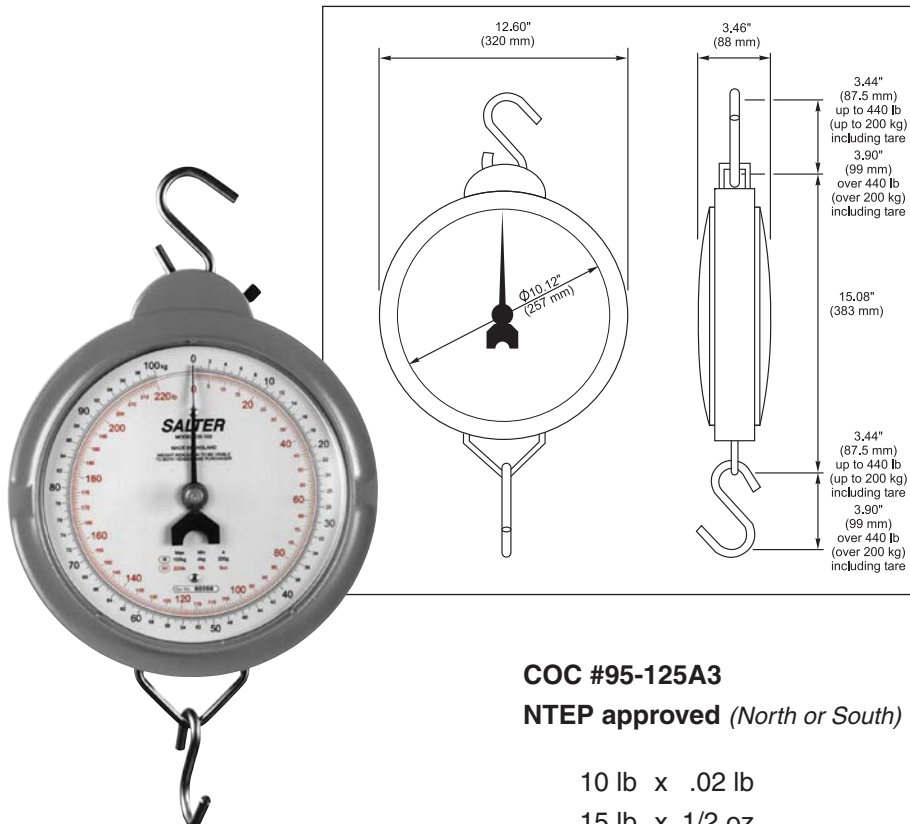
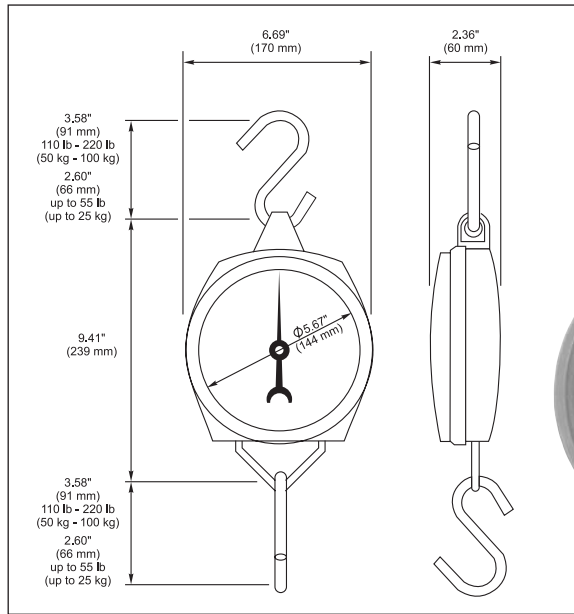

**Model 235 10x (NTEP & Non-NTEP)**

*Heavy duty suspended scale, NTEP approved up to 100 lbs. Easy to read dial housed in a robust die cast casing. Low friction bearings provides positive movement to give maximum sensitivity. Accurate to one part in 500 with up to 10% zero adjustment. Supplied with top and bottom hooks as standard.*

**Option**

*Double lipped scoop  
Round pan  
Galvanized scoop*

**COC #95-125A3**

**NTEP approved** (North or South)

- 10 lb x .02 lb
- 15 lb x 1/2 oz
- 25 lb x .05 lb
- 30 lb x 1.0 oz

**Non-NTEP approved**

- 100 kg x 200 g / 220 lb x 8 oz
- 200 kg x 500 g / 440 lb x 1 lb
- 300 kg x 1 kg / 660 lb x 2 lb

**Galvanized scoop** (16½" x 14" x 6" deep)

*Can be supplied with 235-10X or 235-10S,  
up to 56 lb/25 kg capacity.*



---

**Double lipped stainless steel scoop**

*Can be supplied with 235-10X or 235-10S.*



---

**Round stainless steel pan, 12 in (305 mm diameter)**

*Can be supplied for retrofitting to the 235-6S,  
235-6M, 235-10S, 235-10X, up to 56/25 kg  
capacity*



**Salter Brecknell Weighing Products**

a division of Avery Weigh-Tronix  
1000 Armstrong Dr.  
Fairmont, MN 56031  
Toll free: 800-637-0529  
Tel: 507-238-8702 Fax: 507-238-8271  
e-mail: [sales@salterbrecknell.com](mailto:sales@salterbrecknell.com)  
[www.salterbrecknell.com](http://www.salterbrecknell.com)