

GSE ITA

Integrated Tank Assembly



Setup Instructions

Version 2.0



TABLE OF CONTENTS

OVERVIEW	1
FEATURES / BENEFITS	1
INSTALLATION	1
EXAMPLE APPLICATION.....	2
MAXIMIZE SYSTEM ACCURACY.....	2
ENVIRONMENTAL CONSIDERATIONS	3
NUMBER AND CAPACITY OF LOAD CELLS	3
MECHANICAL.....	4
CALIBRATION	5
MAXIMIZE OPERATIONAL ACCURACY	5
ADDITIONAL CONSIDERATION	5
VESSEL RESTRAINT SYSTEMS.....	5
ITA DIMENSIONS QUICK REFERENCE	7
FIGURE 1: ITA DIMENSIONS 1 K TO 125 K.....	7
FIGURE 2: ITA DIMENSIONS 150 K TO 225 K.....	8
FIGURE 3: MOUNTING PLATE DIMENSIONS 1K - 10K.....	9
FIGURE 4: MOUNTING PLATE DIMENSIONS 20K - 125K.....	9
FIGURE 5: MOUNTING PLATE DIMENSIONS 150K - 225K.....	10
LOAD CELL SPECIFICATIONS	10
MOUNTING SPECIFICATIONS	10
LOAD CELL WIRING	10

OVERVIEW

The Integrated Tank Assembly (ITA) offers the most efficient design for tank weighing.

Unlike the Single and Double Ended Shear Beams, the ITA requires no assembly and is totally self-contained. The ITA is also self checking by design. The ITA can accept a 3-degree off axis angle and remain accurate, however every step should be taken to assure a level plane for the Tank or Vessel. Uplift restraint and side load protection is integral to the ITA.

The ITA is manufactured with Tank Weighing in mind. It is hermetically sealed, stainless steel.

With its versatility and available capacities the ITA will work for most any tank weighing applications.

Available with a captive strain relief or ½" NPT conduit fitting (20 K to 450K only) for load cell cable.

FEATURES / BENEFITS

- Low Profile 1.3" for the 1-10 K to 4.75" for the 225,000 K /
Allows the customer to put the ITA into existing systems with minimal piping modifications.
- Fully Welded, Stainless Steel Construction /
Minimal down time from environmental damage.
- 100% Side load and Uplift restraint, 150% overload protection, 300% ultimate overload. /
Check/Stay restraints not required for many installations.
- 3 degree non-parallel accommodation. /
In place calibration can correct for misalignments.
- Simple design. No cotter pins, screws, or retainers needed. /
No hardware to corrode. Reduces installation errors.
- Round design /
Easy cleaning and less product accumulation.
- Low weight. The larger ITAs weigh 30% less than competitive products. /
Easier to move during installation.
- Efficient use of material. /
Substantial cost savings.

INSTALLATION

Install the ITA as you would most tank mount load cells. The following is a guide to insure maximum performance from your system.

Prepare the ITA: The ITA top Plate must move freely. **Every ITA comes from the factory correctly assembled and locktighted and should not require adjustment.**

The load must be applied vertically to the load cells.

- a. Use a level to insure that the base plate is level. If not, level the supporting points, if this is not possible then shim the load cell base plate.

- b. Use a level to insure that the load cell is level then lower the vessel close to the load cell.
- c. Visually inspect the foot of the vessel support to insure that it aligns evenly with the level load cell. If it does not, shim the foot so that the load cell remains level.

If a temperature insulator is required between the foot and the load cell, use only a rigid isolator. Only the outer load cell ring may contact the foot or insulator.

If the ITA has been disassembled for any reason, perform the following:

- a. Remove the large center screw.
- b. Align the convex load disc and the load cell with the center hole in the base plate.
- c. Locktight and install the large screw and continue to turn it until the Rubber O-Ring just contacts the convex load disc.
- d. Back the screw off ¼ turn. The Screw provides lateral restraint and lift off protection, never remove it or back it off more than the suggested amount.

FYI

The center portion of the ITA load cell mount is not live. Therefore, if any part of the tank leg or adapter plate makes contact with the center, it will affect the weighing accuracy of the system.

Example Application

Example system: 1 tank with 3 legs, absolute capacity of the tank = 2000 gallons, specific gravity of product is 1.2 or 9.6 lbs. Per gallon for a total live load of 19,200 lbs. The dead load (dry weigh of the tank) is 5,000 lb. Therefore the total weight of the system = 24,200 lbs. Divide the total weigh by the number of legs on the vessel $24,200 / 3 = 8067$ lbs. Select the next higher capacity load cell. The appropriate load cell for this example would be 10,000 pounds. Once you have determined the appropriate capacity you need to use, the next consideration is the environment

- If you are in a Food or corrosive chemical environment and/or wash-down is likely, hermetically sealed stainless steel load cells are a must.
- Protection from side impacts from moving equipment allows the use of the lowest capacity load cells appropriate for the system. Higher capacity cells can provide some protection but at a loss of system accuracy.
- In out of doors installations and in areas subject to earthquakes, additional load cell capacity and tank restraints should be considered.

In the above application with an indoor wet environment, the recommendation would be for 3-10,000 lb. ITAs. These cells will provide the necessary protection for both overload and wash-down reasons.

MAXIMIZE SYSTEM ACCURACY

Most weight indicators typically have an error of +/- .01%, hence, the main source of error will be the load cells and, **more importantly, the mechanical arrangement of the scale itself.**

Each installation is unique in terms of the mechanical arrangement, installation site, environmental factors and scale performance. Following are recommendations that contribute to the best accuracy. It may not be possible to comply with all these recommendations, however, they should be kept in mind when designing or installing a system.

Environmental Considerations

- Install the vessel in an environment where temperature fluctuations are minimized and where it will be protected from wind and drafts.
- Use load cells with temperature compensation that will allow the most satisfactory performance.
- Use a shield to protect the load cells from radiant heat sources. Use a rigid insulating pad between the vessel and load cell mount if heat/cold would be conducted from the vessel itself.
- If thermal expansion/contraction of the vessel is expected, choose a mount that will allow lateral movement.
- Avoid an environment where its support structure is subject to vibration. Minimize vibrations and forces transmitted via attached piping or vessel restraints
- Select load cells and mounts with proper corrosion and moisture protection. Fully welded and sealed, stainless steel cells provide excellent protection.
- Use a junction box with appropriate environmental protection.

Number and Capacity of Load Cells

The number of vessel supports determines the number and capacity of the load cells required. It becomes more difficult to get even weight distribution on all supports as the number of load cells increases beyond three.

Examples:

UPRIGHT CYLINDRICAL VESSELS IN COMPRESSION

Three or more symmetrically mounted load cells. Three provides the most even weight distribution between cells. Other factors may require that more supports be used with the vessel for strength or stability. The fewer the number of cells, the easier to distribute the weight evenly.

RECTANGULAR OR HORIZONTALLY MOUNTED CYLINDRICAL VESSELS IN COMPRESSION

Most practical is four cells, one at each corner of the vessel. Other factors may require that more supports be used with the vessel for strength or stability. The fewer the number of cells, the easier to distribute the weight evenly.

SUSPENDED VESSELS (TENSION or COMPRESSION)

One or more load cells may be used. Using three, symmetrically mounted, load cells or fewer has the advantage of not requiring accurate adjustment of the length of the supports to distribute the weight evenly. Other factors may require that more supports be used with the vessel for strength or stability.

- Appropriate individual cell capacity: Calculate Total empty vessel weight + The Maximum that the vessel can hold when filled to overflowing *divided* by the number of supports. Chose a cell that meets or just exceeds this calculation. If the vessel is mounted out of doors, additional capacity may be required to protect from wind induced overload.
- Do not needlessly oversize the load cells; Best accuracy is achieved when maximum weighing is close to the load cells capacity.

- If it is not possible to trim the corners before or after installation then the use of load cells with matched outputs is desirable. If the vessel is not symmetrical and/or the material is not self-leveling, trimming or matching is a necessity for accuracy.
- Support the vessel entirely on load cells; do not use dummy cells or flexures that would hinder good performance.

Mechanical

- Support the load cell mounts on a rigid structure so that all points are equally supported and the vessel stays vertical. Vehicular traffic or other forces must not cause deflection of the vessel's support structure.
- Ladders, pipes and check rods, etc. must have as little interaction with the vessel as possible.
- Where piping or conduit must be attached to the vessel: Use the smallest diameter, thinnest walled pipe that will meet all other specifications. Use the longest reasonable unsupported **horizontal** length to connect the vessel. 25 times the pipe diameter as a minimum to the first support or use a **horizontally** mounted flexible connection.
- There must be no tension between electrical cables or hoses and the vessel.
- Mount pneumatic solenoids for integral gates or valves **on the vessel** then connect the supply lines horizontally as in piping.
- Attached piping is usually the largest source of error in vessel weighing. The lower the capacity of the vessel the more likely inaccuracies of this type will be apparent. Correctly installed piping and electrical connections followed by an in place calibration will result in the best system performance

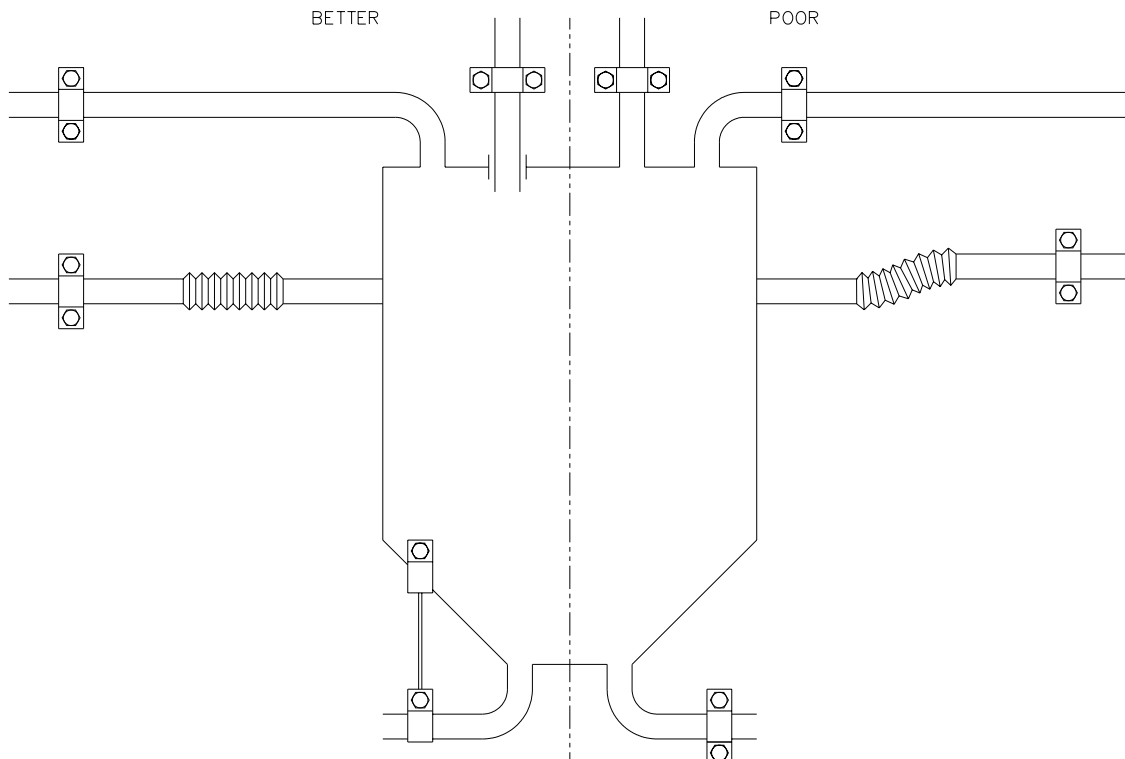

Calibration

- Ideally the vessel will have a means of hanging weight from the corners of the vessel to trim the load cell outputs and for calibration. If it is not possible use test weights to calibrate, a known amount of product or substitute should be used.
- Calibration in place can help compensate for interference from piping, electrical connections and slightly misaligned load cells.

MAXIMIZE OPERATIONAL ACCURACY

- **Use GSE Future Gross. This feature calculates the cutoff point based on current flow rate and a manually entered freefall time.**
- An evenly flowing material can be most accurately measured. Reduce to a minimum the surging (i.e. diaphragm pump) of liquids while a weight reading is being taken.
- Slow down the filling cycle as much as possible or use a 2-speed fill cycle to reduce to a minimum the amount of freefall material when nearing the cutoff.
- If possible, switch off any vibrating or mixing equipment while the weight is being determined.

ADDITIONAL CONSIDERATION

VESSEL RESTRAINT SYSTEMS



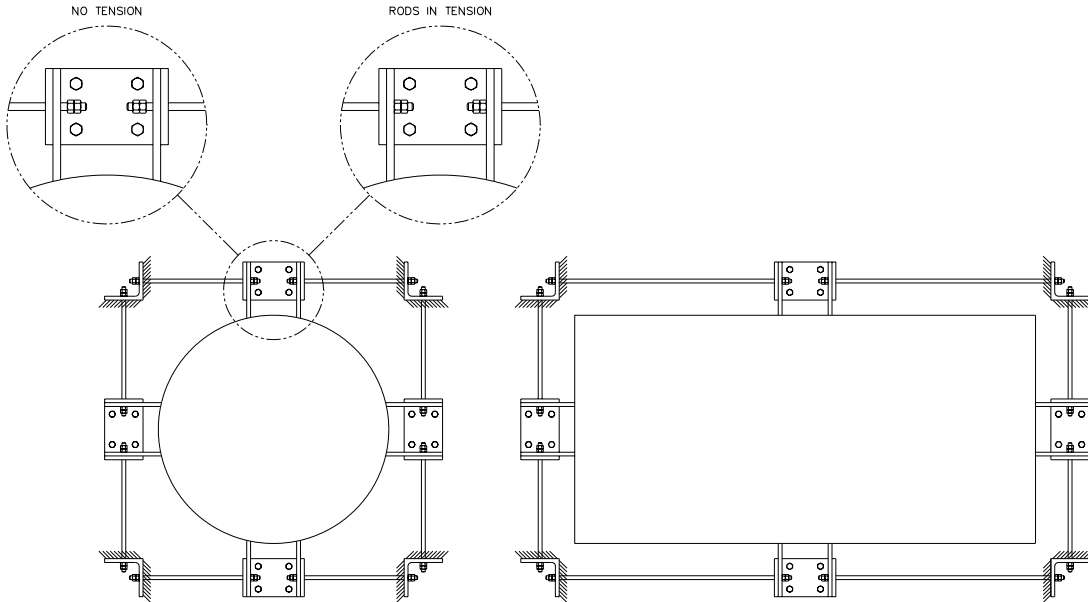

ITAs are self checking with integral lift off restraint, however, additional vessel restraints may be required to prevent a vessel from falling from unexpected forces, protect connections from fatigue or to keep connections aligned.

Check Rods and Stay Rods can be identical with the exception of the actual connection to the vessel. The following Table lists their traits and uses.

Check Rods	Stay Rods
Prevent excessive Motion	Prevent any Horizontal Motion
Can be mounted Vertically for suspended vessels. Used to prevent falling in case of a catastrophic load cell failure.	Cannot be used vertically
Mounting is Tangential for Circular Vessels – Parallel for Rectangular Vessels	
Installed without Tension or Compression	Installed with slight Tension
Should have no effect on accuracy	Should have minimal effect on accuracy. Length and diameter of the rod directly influences this. Use the longest, thinnest rod of suitable strength.

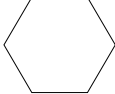
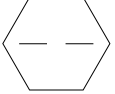

Never Exceed Recommended Bolt torque. An over torqued bolt can be structurally weakened.

LC ...Low Carbon MC...Medium Carbon Q...Quenched T...Tempered Steel A...Alloy						
	SAE 0-2 LC 74000 PSI	SAE 3 MC 100000 PSI	SAE 5 MC T 120000 PSI	SAE 6 MC QT 133000 PSI	SAE 7 MC QTA 133000 PSI	SAE 8 MC QTA 150000 PSI
Bolt-Coarse *Fine	Approximate Dry Torque Coarse / Fine					
1/4-20 *28	4/6	9/10	10/11	10/12	10/12	12/14
5/16-18 *24	9/12	17/19	19/21	21/23	21/24	25/29
3/8-16 *24	16/22	30/33	33/36	39/44	40/45	45/50
7/16-14 *20	24/34	47/51	54/59	60/69	60/70	70/80
1/2-13 *20	38/52	69/75	78/85	94/99	95/100	110/120
9/16-12 *18	52/71	103/112	114/124	133/147	135/150	150/170
5/8-11 *18	98/115	145/158	154/168	135/205	140/210	220/240
3/4-10 *16	155/180	234/255	257/280	310/350	320/360	380/420
7/8-9 *14	206/230	372/405	382/416	500/560	520/580	600/660
1-8 *14	310/350	551/600	587/640	780/840	800/860	900/990
1 1/8-7 *12	480/523	794/865	872/950	1305/1425	1325/1444	1430/1559
1 1/4-7 *12	675/736	1105/1204	1211/1320	1790/1950	1825/1989	1975/2153
1 3/8-6 *12	900/981	1500/1635	1624/1770	2425/2655	2500/2725	2650/2888
1 1/2-6 *12	1100/1200	1775/1935	1943/2118	2915/3175	3000/3270	3200/3488
Lubrication Factors	Zinc Plate	Cadmium Pl	Chrome Pl	Dry Film	Oil	Oil/Graphite
	-15%	-25%	N/C	-50%	-15-40%	-55%

ITA DIMENSIONS QUICK REFERENCE

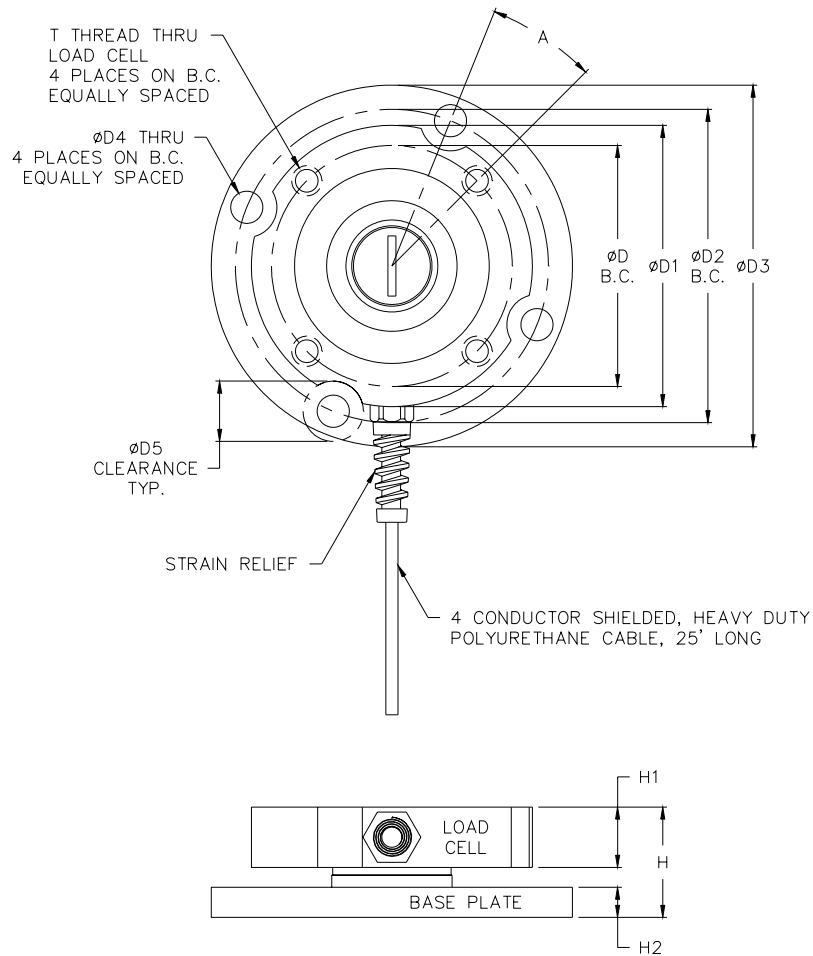

RATED CAPACITY (LBS)	H	H1	H2	D	D1	D2	D3	D4	D5	A	T
1K - 10K	1.37	0.75	0.375	3.000	3.50	3.900	4.50	0.400	0.75	23.0°	3/8-16
20K - 50K	2.53	1.30	0.75	4.825	5.50	6.250	7.00	0.563	1.25	17.0°	1/2-13
60K - 125K	3.12	1.50	1.00	5.500	6.50	7.000	8.00	0.813	1.75	52.5°	3/4-16

Figure 1: ITA Dimensions 1 K to 125 K

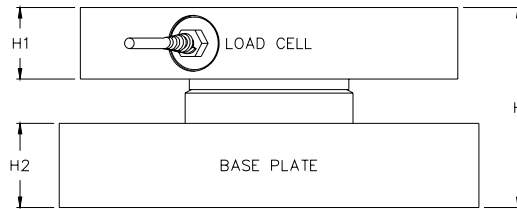
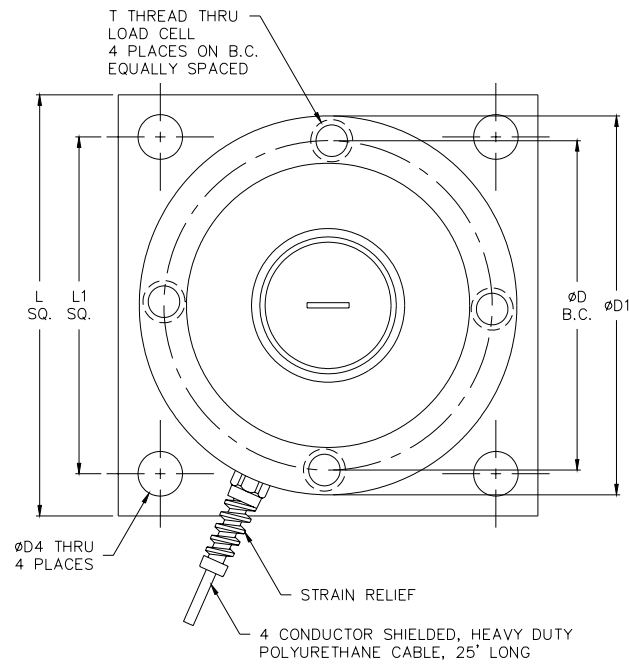

RATED CAPACITY (LBS)	H	H1	H2	L	L1	D	D1	D4	T
150K - 225K	4.75	1.70	2.00	10.00	8.00	7.825	9.00	1.06	1-12

Figure 2: ITA Dimensions 150 K to 225 K

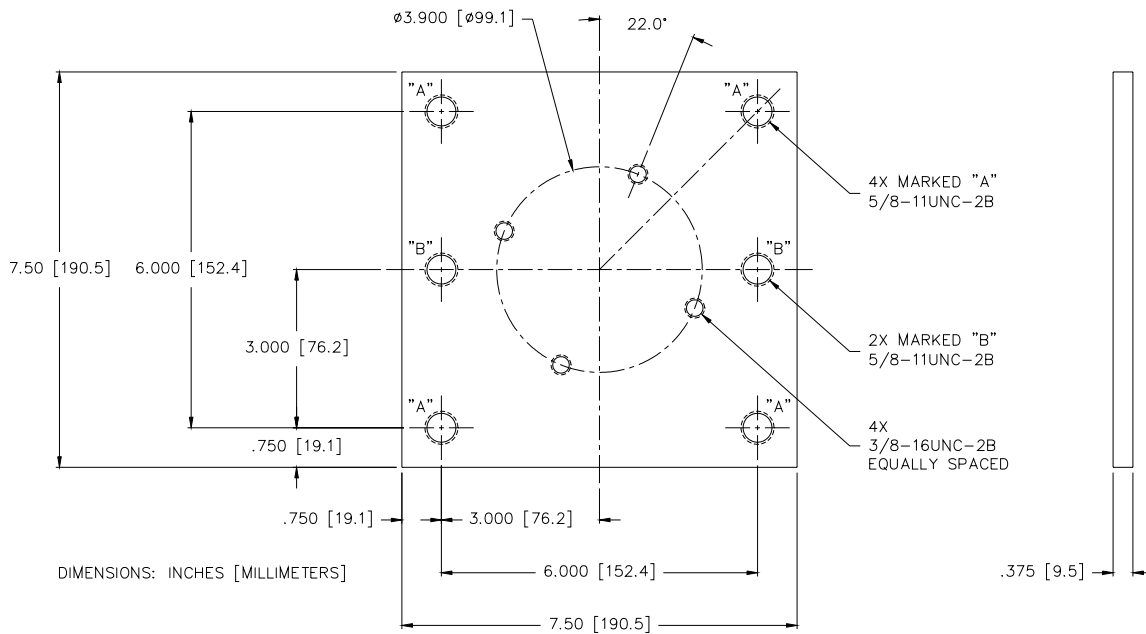

Figure 3: Mounting Plate Dimensions 1K - 10K

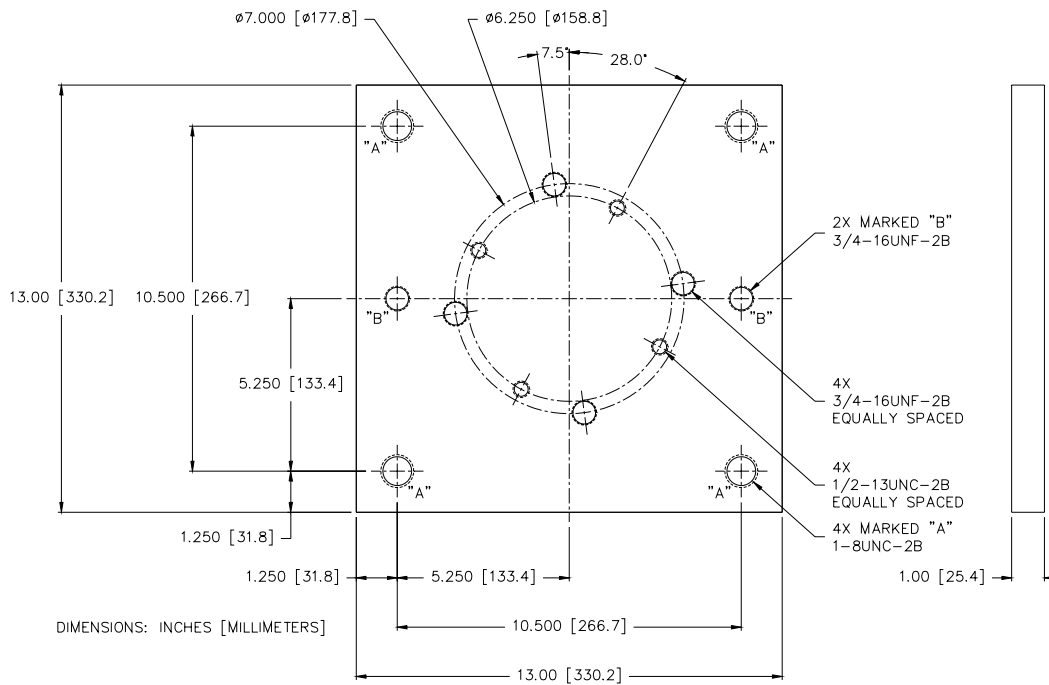

Figure 4: Mounting Plate Dimensions 20K - 125K

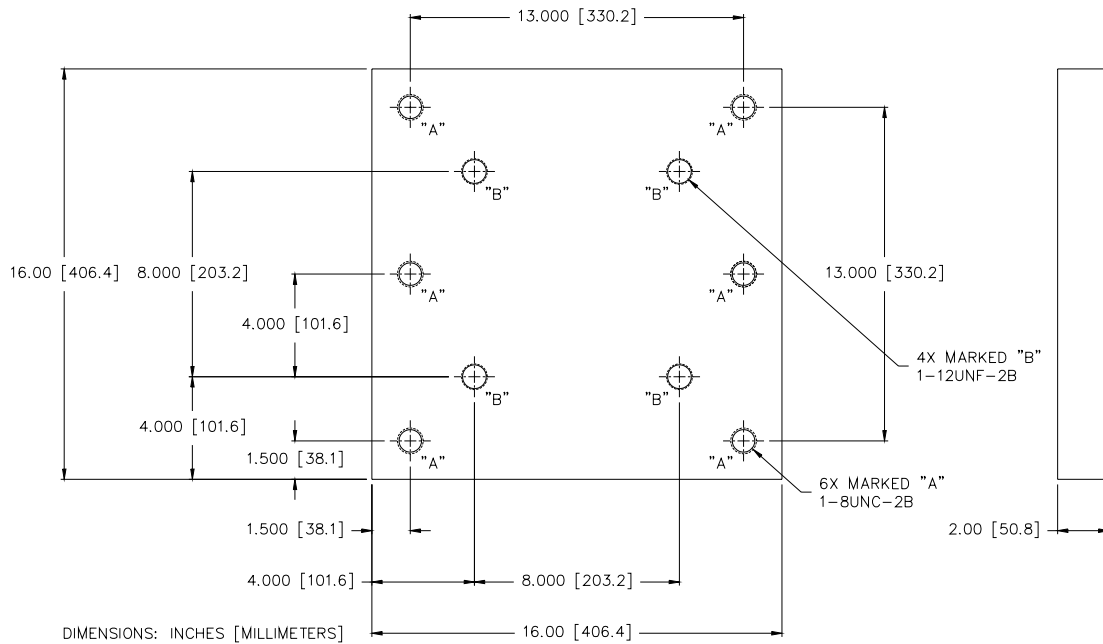

Figure 5: Mounting Plate Dimensions 150K - 225K

Load Cell Specifications

	1K to 10 K	20 K to 50 K	60 K to 125 K	150 K to 225 K
Construction	Stainless Steel, Hermetic	Stainless Steel, Hermetic	Stainless Steel, Hermetic	Stainless Steel, Hermetic
Exc. Voltage	10 – 15 VDC or VAC	10 – 15 VDC or VAC	10 – 15 VDC or VAC	10 – 15 VDC or VAC
Output	3 mV/V nominal	3 mV/V nominal	3 mV/V nominal	3 mV/V nominal
Temp Range	10° F to 100° F	10° F to 100° F	10° F to 100° F	10° F to 100° F
Bridge Resistance	350 Ohms nominal	350 Ohms nominal	350 Ohms nominal	350 Ohms nominal
Insulation Resistance	5000 Meg Ohms min	5000 Meg Ohms min	5000 Meg Ohms min	5000 Meg Ohms min
Linearity	0.05 % Full Scale	0.05 % Full Scale	0.05 % Full Scale	0.05 % Full Scale
Repeatability	0.01 % Full Scale	0.01 % Full Scale	0.01 % Full Scale	0.01 % Full Scale
Max load safe	150 % of rated capacity	150 % of rated capacity	150 % of rated capacity	150 % of rated capacity
Max Load ultimate	300 % of rated capacity	300 % of rated capacity	300 % of rated capacity	300 % of rated capacity

Mounting Specifications

	1K to 10 K	20 K to 50 K	60 K to 125 K	150 K to 225 K
Uplift Restraint	100 % of rated capacity	100 % of rated capacity	100 % of rated capacity	100 % of rated capacity
Lateral Restraint	100 % of rated capacity	100 % of rated capacity	100 % of rated capacity	100 % of rated capacity
Non- Parallel Accommodation	± 3 °	± 3 °	± 3 °	± 3 °
Thermal Accommodation	± .1 °	± .17 °	± .2 °	± .25 °

Load Cell Wiring

+ Excitation	Green
- Excitation	Black
+ Signal	White
- Signal	Red

PART NUMBER
39-10-42089