

---

AIRLINE BAGGAGE SCALE

# *ABS 4100*

Technical Reference Manual 2.0





# *ABS 4100*

Technical Reference Manual 2.0

# **ABS 4100 Airline Baggage Scale Reference Manual**

Copyright © 2000 GSE Scale Systems. All rights reserved.

Published by:

GSE Scale Systems  
42860 Nine Mile Road  
Novi, MI 48375  
USA

Information in this *Reference Manual* is subject to change *without notice* due to correction or enhancement. The information described in this manual is solely the property of GSE. No part of this manual may be reproduced or transmitted in any form or by any means, electronic or mechanical, including photocopying and recording and sold for any monetary figure without the express written permission of GSE.

## **GSE Locations Worldwide**

### **GSE Scale Systems**

42860 Nine Mile Road  
Novi, MI 48375  
U.S.A.  
Phone: (800) 755-7875  
[www.gse-inc.com](http://www.gse-inc.com)

### **GSE Scale Systems**

Mechanical Systems Division  
914 SE 14<sup>th</sup> Place  
Cape Coral, FL 33990 USA  
Phone: (800) 237 - 6284

### **GSE Canada, Inc.**

617 East Lake Road  
Airdrie, Alberta Canada T4B 2B8  
Phone:(403) 948-9921  
Fax: (403) 948-1449

### **GSE Advanced Industrial Technologies GmbH**

Hausinger Strasse 4  
Langenfeld, Germany 40764  
Phone: (49) 21 739 16399-0  
Fax: (49) 21 739 16399-9

# CONTENTS

<b>CHAPTER 1: INTRODUCTION</b> .....	<b>1</b>
CONVENTIONS AND SYMBOLS.....	1
DISPLAY .....	2
<i>Annunciators</i> .....	2
KEYPAD .....	3
KEYPAD FUNCTIONS.....	3
SPECIFICATIONS.....	5
<b>CHAPTER 2: INSTALLATION</b> .....	<b>7</b>
MOUNTING.....	7
<i>Load Cell Connections</i> .....	10
<i>Serial Port Connections</i> .....	11
<b>CHAPTER 3: ABS 4100 CONFIGURATION</b> .....	<b>15</b>
SETUP MODE .....	15
SELECTION PARAMETERS.....	18
KEY-IN PARAMETERS.....	19
PARAMETER MAP.....	20
<i>Parameter Map Details</i> .....	22
CUSTOM TRANSMIT SETUP .....	28
<i>Elements of a Custom Transmit</i> .....	28
<i>Writing a custom transmit ASCII text file</i> .....	28
<i>Accessing Setup and Clearing Existing Custom Transmit</i> .....	28
<i>Entering ASCII Text</i> .....	29
<i>Entering ASCII Control Codes</i> .....	29
<i>Exiting Setup Mode and Saving Changes</i> .....	32
<i>Display Capture Utility</i> .....	33
GENERAL SETUP AND OPERATION .....	34
<i>Baggage Weighing and accumulation</i> .....	35
RS-485 MULTI-DROP NETWORK SETUP AND OPERATION.....	36
<i>Setup</i> .....	36
<i>Operation</i> .....	36
<i>Network Protocol</i> .....	37
<b>CHAPTER 4: CALIBRATION MODE</b> .....	<b>39</b>
SETUP MODE CALIBRATION .....	39
FAST CALIBRATION .....	39
PERFORMING CALIBRATION .....	40
<i>Establishing Zero</i> .....	40

<i>Establishing Span</i> .....	46
<i>Exiting Calibration</i> .....	46
<b>CHAPTER 5: LEGAL-FOR-TRADE.....</b>	<b>49</b>
NTEP REQUIREMENTS.....	49
OIML REQUIREMENTS.....	49
OTHER REQUIREMENTS.....	50
SEALING AND AUDIT TRAILS.....	50
<i>Physical Seal</i> .....	51
<i>Audit Trails</i> .....	52
<b>CHAPTER 6: ABS 4100 OPTION.....</b>	<b>55</b>
RS-485 NETWORKING.....	55
<i>Network Connections</i> .....	56
<b>CHAPTER 7: TROUBLESHOOTING.....</b>	<b>60</b>
ERROR MESSAGES .....	60
<i>Operational Errors</i> .....	60
<i>Setup Mode Errors</i> .....	61
<i>Hardware Errors</i> .....	62
<i>Calibration Errors</i> .....	62
<i>Communication Errors</i> .....	63
<i>Miscellaneous Errors</i> .....	63
VIEWING SETUP .....	63
INFORMATION MODE PARAMETERS .....	64
A/D CALIBRATION PROCEDURE .....	66





# CHAPTER 1: INTRODUCTION

Thank you for selecting the GSE ABS 4100 Airline Baggage Scale. The ABS 4100 continues the GSE tradition of *Excellence in Weighing Technology*. A properly installed and maintained ABS 4100 will provide many years of reliable, accurate performance.

The chapters of this manual focus on various aspects of the indicator:

<b>Chapter 1: Introduction</b>	Basic operating information.
<b>Chapter 2: Installation</b>	Installation instructions.
<b>Chapter 3: Configuration</b>	Access the Setup Mode and configure the indicator to a specific application.
<b>Chapter 4: Calibration</b>	Access the Calibration Mode and match the load sensing device to the indicator.
<b>Chapter 5: Legal-for-Trade</b>	Legal-for-trade information.
<b>Chapter 6: Options</b>	Lists available options..
<b>Chapter 7: Troubleshooting</b>	Troubleshooting help and error messages.

## CONVENTIONS AND SYMBOLS

Although the ABS 4100 displays alpha characters in both upper and lower case, conventional capitalization is used when referencing display prompts.

<b>[CLEAR TOTAL]</b>	A keypress appears in bold with brackets.
<b>200 [CLEAR TOTAL]</b>	Numeric entries are also in bold.
<b>[CLR]+[CLEAR TOTAL]</b>	'+' indicates keys pressed simultaneously.
<i>Setup</i>	Display prompts are bold italic.
<i>Setup ~ Enter ~ =Cal!</i>	'~' indicates multi-part display prompts.
<i>Fast ~ Cal!</i>	Display prompts can appear in sequence.
<i>First ~ 0? ~ 0.00</i>	



Indicates important considerations.



Provides additional information.

## DISPLAY

The ABS 4100 comes with (2) six digit, 7-segment red LED displays with 3 annunciators on each display to show weight, units and status information. The ABS 4100 displays alpha-numeric data, but due to the nature of 7-segment LED display and the limitation of six digits, some information is abbreviated.

All segments and annunciators are illuminated for a brief display test upon power up. The current gross weight is then displayed in default units.

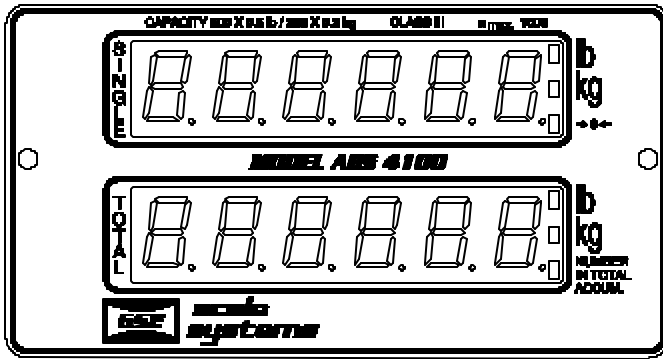

Figure 1-1: ABS 4100 Display

## ANNUNCIATORS

Annunciators provide mode and status information. When illuminated, they indicate the following conditions:

- Lb** The displayed value is represented in pounds. Used on both the Single and Total displays.
- Kg** The displayed value is represented in kilograms. Used on both the Single and Total displays.
- 0←** Displayed weight is at center-of-zero ( $\pm \frac{1}{4}$  display graduation).
- NUMBER IN** Total number of bag accumulations performed.
- TOTAL ACCUM.**

## KEYPAD

A sealed 5-button elastomer keypad is used for operator input. Each key is assigned two distinct functions. Various key combinations are also used.

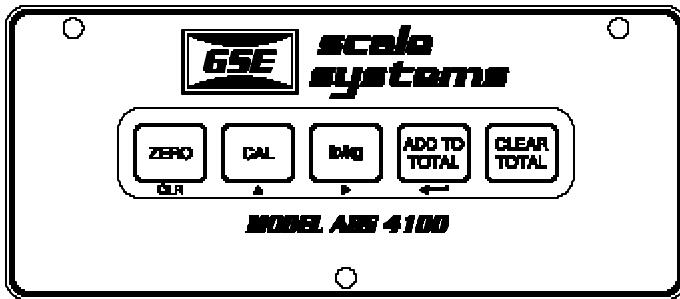

Figure 1-2: ABS 4100 Keypad

## KEYPAD FUNCTIONS

The ABS 4100 keypad has five primary Weigh Mode functions:

<b>[ZERO]</b>	Performs a gross zero and selects the gross mode.
<b>[CAL]</b>	Will perform a calibration with one keypress. See <i>Chapter 4</i> for calibration information.
<b>[lb/kg]</b>	Toggles the units of measure between 'lb' and 'kg'.
<b>[ADD TO TOTAL]</b>	Performs an accumulation and adds that accumulation to the total.
<b>[CLEAR TOTAL]</b>	Clears the accumulation total and bag count.

*Table 11: Keyboard Functions*

<b>Key Press</b>	<b>Weigh Mode</b>	<b>Setup Mode</b>
<b>[ZERO / CLR]</b>	Performs a gross zero function and/or clears an entry in progress.	Exits the Setup Mode and/or answers “NO” to query prompts and/or clears an entry in progress.
<b>[CAL / ▲ ]</b>	Performs a calibration Refer to Chapter 4 for details .	‘Scrolls’ through digits during data entry.
<b>[lb/kg / ► ]</b>	Toggles between ‘lb’ and ‘kg’ and/or advances cursor to next entry position.	Advances cursor to next entry position and/or cycles prompts.
<b>[ADD TO TOTAL/↵ ]</b>	Performs an accumulation and adds that value to the total accumulation display and register.	Accepts an entry in progress and/or ‘scrolls’ through parameter sub-set selections and/or answers ‘YES’ to query prompts.
<b>[CLEAR TOTAL]</b>	Clears the accumulation total and bag count.	Advances to the next setup parameter.
<b>[ZERO]+ [CLEAR TOTAL]</b>	Access Setup Mode.	No function.
<b>[ADD TO TOTAL]+ [CLEAR TOTAL]</b>	No function.	Return to the previous setup parameter.
<b>[ZERO]+ [ADD TO TOTAL]</b>	Absolute clear – clears an entry in progress and/or clears the value of a parameter.	Clears any entry in progress.
<b>[ZERO]+ [CAL]</b>	Backspace – erases the right-most digit during data entry.	Backspace – erases right-most digit during data entry.
<b>[CAL]+ [lb/kg]</b>	Reverse character scroll during data entry.	Reverse character scroll during data entry.

## SPECIFICATIONS

### PERFORMANCE

Full Scale (F.S.)	Selectable 0 to 999,990
Resolution	20-bit A/D converter, 100,000d displayed ±500,000d internal
A/D Conversion	60 Hz
Zero Track	0 – 100% of F.S.
Operating Temperature	-10°C to +40°C
Units of Measure	lb, kg

### ELECTRICAL

Excitation Voltage	85 – 265VAC, 0.5A; 50/60 Hz
Excitation Current	10 VDC
F.S. Signal Input	180 mA max. / (6) 350Ω bridge
Signal Connection	0.1 mV/V min – 20 mV/V max 4 lead or 6 lead with sense

### COMMUNICATIONS

Serial	RS232 bi-directional serial port
Data Output	14 selectable fixed-format transmissions or 1 custom format (programmable via RS232)
Protocol	Selectable
Baud Rate	150 – 9600 bps

### DISPLAY

LED	(2) 6-digit weight displays, 0.8” (22mm) height 3 LED annunciators on each display for operational status
-----	--

### KEYPAD

5-button elastomer

### ENCLOSURE

Conductive black powder coat

### OPTIONS

Cables	Standard RS 232 type to interconnect between the display, keypad and electronics.
--------	---



## CHAPTER 2: INSTALLATION

This chapter contains information necessary for proper installation of the ABS 4100. Please review these instructions before installing your controller.

High voltages may exist within the enclosure. To prevent the risk of electrical shock, ALWAYS unplug the ABS 4100 when opening the enclosure. Installation and servicing of the ABS 4100 should be performed only by authorized and qualified service personnel.

For NTEP and OIML details, see *Chapter 5: Legal-for-Trade*.



**IMPORTANT!** The ABS 4100 Airline Baggage Scales do not include an on/off switch and therefore must be installed near a power outlet socket that is easily accessible and in keeping with UL/CSA Safety Standards.

**INFORMATION IMPORTANT!** Prendre note que les contrôleurs de ABS 4100 ne sont pas munis d'interrupteurs "Marche / Arrêt". Par conséquent, il devront être installés près d'une source d'alimentation secteur accessible pour demeurer sous les exigences des normes de sécurité UL/CSA.

### MOUNTING

The ABS 4100 has three separate components . The housing with the main board installed, the display unit and the keypad. All components can be installed in separate locations. The following figures show the outline drawings for each component. Each main unit comes with 10 labels for the SYSTEM SERIAL NO. Be sure to place the label on the front of each component being installed. See **Error! Reference source not found.** for details.



**WARNING!** Be sure to disconnect AC power from the main module before installing keypads and display modules.

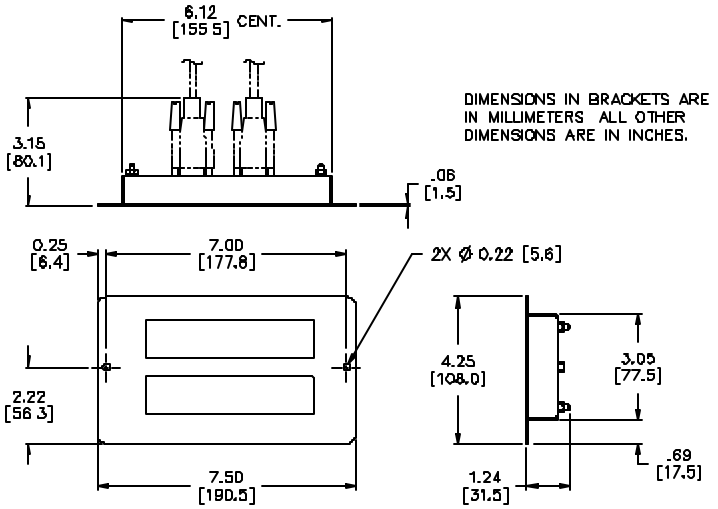

Figure 2-3: ABS 4100 Display Outline Drawing

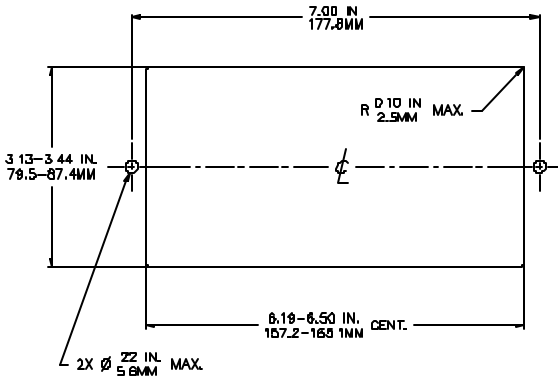

Figure 2-4: ABS 4100 Display Module Cutout

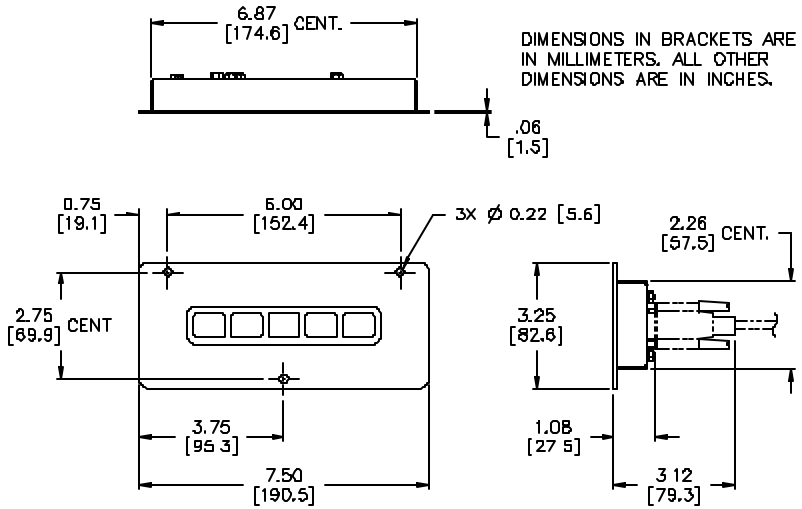

Figure 2-5: ABS 4100 Keypad Outline Drawing

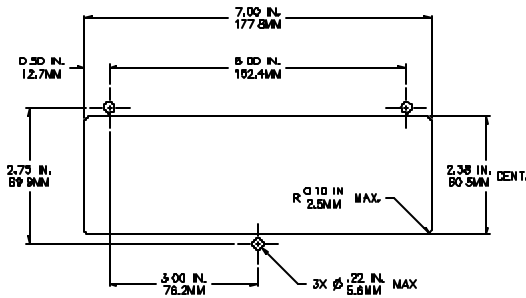

Figure 2-6: ABS 4100 Keypad Cutout

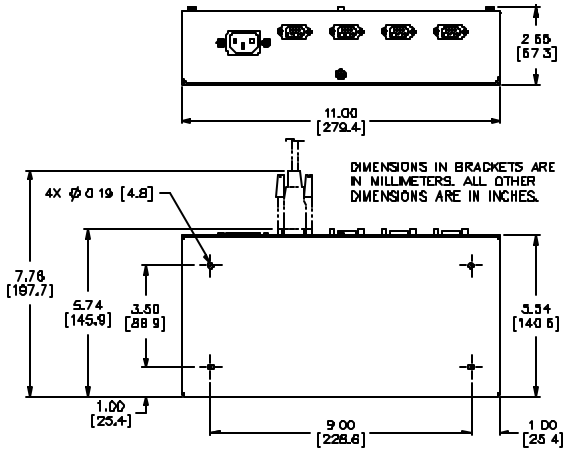

Figure 2-7: ABS 4100 Main Board Outline

### LOAD CELL CONNECTIONS

A high quality braided shield cable with 16 to 24 AWG stranded wire is recommended for load cell or summing box connections. Either four or six conductor cables can be used.

**When using four conductor cables, (+ Excitation) must be connected together with (+ Sense), and (- Excitation) must be connected together with (- Sense).** Utilizing the (+) and (-) Sense leads of six conductor cables provides compensation for variations in the excitation voltage due to resistance changes in the cable.

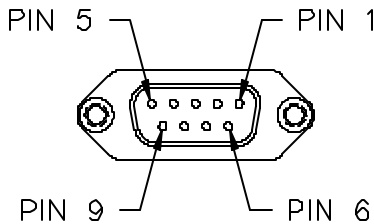

Figure 2-8: Load Cell Connector

Table 2-1: Load Cell Connections

Pin	Description
1	No connection
2	+ Sense
3	- Signal
4	+ Excitation
5	Ground
6	- Excitation
7	+ Signal
8	- Sense
9	No connection

### SERIAL PORT CONNECTIONS

Before connecting to the serial port, consideration should be given to the communication protocol and to any remote key requirements. For information on remote key operation, refer to *Remote Key Operation* on page 32. Use Table 2-2 to determine proper wiring to the communication port.

Communication connections are made through the DB9 male connector marked “Com Port”. The cable should be 20 to 28 AWG with a braided or foil shield for either model type. For maximum noise immunity, use a mating DB9 connector with a metal hood and a braided shield cable. Ensure that the braid makes good connection with the hood. The maximum recommended cable length is 50 feet (15 meters). However, much longer connections are possible if using a properly shielded, low-capacitance cable.

Table 2-2: Serial Port Connections

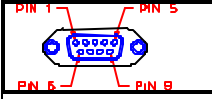
	Description
1	Remote Key
2	Receive
3	Transmit
4	+5 VDC
5	Digital Ground
6	Digital Ground
7	Request-to-Send
8	Clear-to-Send
9	Do Not Connect

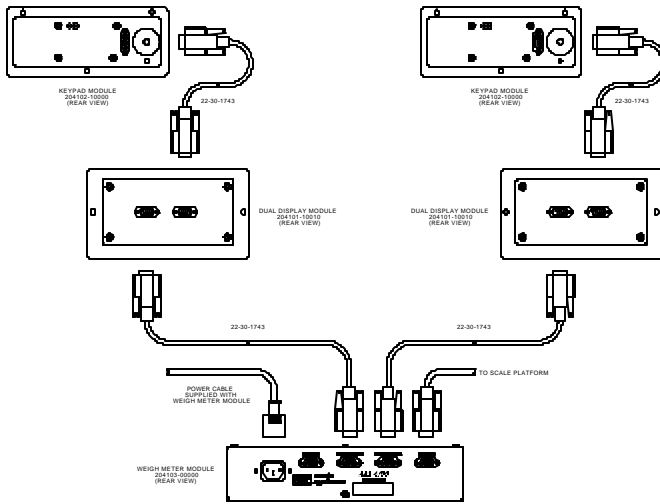

Figure 2-9: ABS 4100 Cable Connection

The ABS 4100 is capable of handling two displays and two keypads. The displays will be connected to the main board enclosure (the connector is labeled *remote display*). Each keypad will be connected to a display. Ports also exist for the load cell and computer connections.





## CHAPTER 3: ABS 4100 CONFIGURATION

For the indicator to operate properly, you must configure a group of specific, individually numbered parameters. There are three types of parameters: Selection Parameters, Toggle Parameters and Key-In Parameters. Assigning a value to a parameter tells the indicator how to respond to a specific situation. See *Table 3-1* for a complete list of all parameters.

### SETUP MODE

To access the setup mode with the keypad, the configuration switch on the keypad must be set to “YES”. See *page 50* for details on Sealing and Audit Trails on Legal for Trade applications.

To prevent accidental changes to the Indicator Setup, a sequence of keystrokes is used to gain access to the Setup Mode:

**[ZERO] + [CLEAR TOTAL], [CLEAR TOTAL], [ZERO], [CAL], [lb/kg], [ADD TO TOTAL]**

These keystrokes must be made within five seconds, or the indicator will return to the Weigh Mode.

#### To access the Setup Mode:

1. From the Weigh Mode, press **[ZERO] + [CLEAR TOTAL]**.  
*Setup ~ Enter Code*
2. Press **[CLEAR TOTAL]**.  
*S*
3. Press **[ZERO]**.  
*SZ*
4. Press **[CAL]**.  
*SZP*
5. Press **[lb/kg]**.  
*SZPU*
6. Press **[ADD TO TOTAL]**.  
*Chgs ~ Poss!*  
*P110.— — ~ F.S.= ~ 100*

**To access Setup in a view-only mode:**

1. From the Weigh Mode, press **[ZERO] + [CLEAR TOTAL]**.  
*Setup ~ Enter Code*
2. Press **[ADD TO TOTAL]**.  
*No ~ Chgs*  
*P110.— — ~ F.S.= ~ 100*



When exiting the Setup Mode, the ABS 4100 prompts whether to enter the Calibration Mode. (See *Chapter 4* for Calibration Mode procedures). The display will then prompt to save any changes.

**To advance to the next parameter:**

1. Press **[CLEAR TOTAL]**.  
*P111.09 ~ 1Grad ~ 0.01*
2. Press **[CLEAR TOTAL]**.  
*P112.05 ~ Ztrac ~ 0.5 d*
3. Continue pressing **[CLEAR TOTAL]** to advance through all setup parameters.

**To access the previous parameter:**

1. Press **[CAL]**.  
.
2. Press **[CLEAR TOTAL]**.  
*P111.09 ~ 1Grad ~ 0.01*
3. Repeat **[CAL] [CLEAR TOTAL]** to back up one parameter.



When accessing a parameter, the parameter number appears briefly. The display then toggles between the parameter name and selection. Pressing **[lb/kg]** will again briefly display the parameter number.

**To access a specific parameter (for example P200):**

1. Press [CAL] four times to select the first digit.  
*2*
2. Press [lb/kg] to advance to the next digit.  
*2.*
3. Press [CAL] once to select the next digit.  
*20*
4. Press [lb/kg] to advance to the next digit.  
*20.*
5. Press [CAL] once to select the next digit.  
*200*
6. Press [CLEAR TOTAL] to advance to the parameter.  
*P200.00 ~ Baud ~ 9600*



For information on accessing information parameters (P60000 – P65002), see *Information Mode Parameters* on page 64.

**To exit the Setup Mode and save changes:**

1. Press [ZERO] to begin exiting Setup Mode.  
*Enter ~ =CAL!*
2. Press [CLR] to bypass Calibration Mode.  
*Enter ~ =Stor*
3. Press [ADD TO TOTAL] to save setup changes.  
*Enter ~ =End*
4. Press [ADD TO TOTAL] to complete exit.  
*0.00*

**To exit the Setup Mode from the view-only mode:**

1. Press [ZERO] to begin exiting Setup Mode.  
*Enter ~ =End*
2. Press [ADD TO TOTAL] to complete exit.  
*0.00*

**To exit the Setup Mode without saving changes:**

1. Press [**ZERO**] to begin exiting Setup Mode.  
*Enter ~ =CAL!*
2. Press [**CLR**] to bypass Calibration Mode.  
*Enter ~ =Stor*
3. Press [**CLR**] to exit *without* saving changes.  
*Enter ~ =Undo*
4. Press [**ADD TO TOTAL**] to undo changes.  
*Enter ~ =End*
5. Press [**ADD TO TOTAL**] to complete exit.  
*0.00*

**SELECTION PARAMETERS**

Selection parameters have a pre-defined list of choices to pick from. Each choice is numbered and corresponds to a certain value. The choice number is shown to the right of the decimal point within the parameter number. Repeatedly pressing [**←**] [**ADD TO TOTAL**] while viewing a selection parameter cycles through the available choices, or you can key in the choice number.

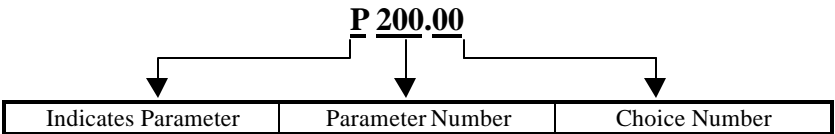

For example, parameter 200 is a selection parameter that holds the baud rate for the serial. This is a selection parameter because a choice number between 00 and 06 must be used. Each choice number corresponds to a different baud rate. To change the baud rate from the default value of 9600 to 4800, perform the following steps from the Setup Mode.

**To change the baud rate from the default value of 9600 to 4800:**

1. Press **200** [**CLEAR TOTAL**].  
*P200.00 ~ Baud ~ 9600*
2. Press [**ADD TO TOTAL**] once.  
*P200.01 ~ Baud ~ 4800*

## KEY-IN PARAMETERS

Key-In Parameters are not limited to a list of choices, although there may be upper and lower value limits. A Key-In Parameter requires that a numeric value be entered using the front panel keys. Key-In Parameters are shown with two hyphens after a decimal point within the parameter number.

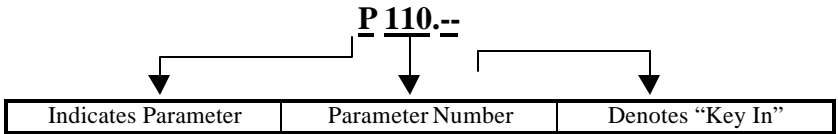

### To enter a Key-In Parameter:

1. Press [▲]. A decimal point is used to represent the entry position.
2. Press [▲] until the desired character appears.
3. Press [▶]. Another decimal point indicates the next entry position.
4. Repeat steps 1 and 2 until your desired entry value is shown.
5. Press [↵] to enter your numerical value.

### To setup a full scale value of 250 lbs:

1. Press **110** [SELECT].  
*P110.— — ~ F.S. = ~ 100*
2. Press [▲] four times to select the first digit.  
*2*
3. Press [▶] to advance to the next digit.  
*2.*
4. Press [▲] six times to select the next digit.  
*25*
5. Press [▶] to advance to the next digit.  
*25.*
6. Press [▲] once to select the next digit.  
*250*
7. Press [↵] to enter the value.  
*P110.— — ~ F.S. = ~ 250*

## PARAMETER MAP

Table 3-1: Parameter Map

Parameter Number	Display Name	Default Value	Valid Range/ Choices	Parameter Description	Page
P110.--	<i>F.S.=</i>	100.00	.01 – 999,999 (Keyed In)	Full Scale	22
P111.09	<i>IGrad</i>	.01	.00001 – 500 (24 Selections)	Count By	22
P112.05	<i>Ztrac</i>	0.5d	Off – 20.0d (200 Selections)	Zero Track Aperture	22
P114.10	<i>Stabl</i>	1.0d	Off – 20.0d (200 Selections)	Stability Window	22
P116.04	<i>Filtr</i>	1 Sec	.065 – 8.00 Sec (8 Selections)	Filter Setting	22
P117.01	<i>Rate=</i>	0.1 Sec	0.05 – 20.0 Sec (201 Selections)	Display Update	23
P118.12	<i>Zrang</i>	100%	.01 – 100% (13 Selections)	Zero Button Range	23
P150.00	<i>Units</i>	lb	lb / kg (Toggle)	Default (Calibration) Units	23
P151.01	<i>Unbut</i>	Enable	Enable / Disable (Toggle)	Units Button	23
P164.03	<i>Acrl2</i>	0.1 P	.01 - 100	Accumulate Return to Zero	23
P200.00	<i>Baud</i>	9600	150 – 9600 (7 Selections)	Comm Baud Rate	23
P201.01	<i>Data</i>	8 Bits	7 – 8 Bits (2 Selections)	Comm Data Bits	23
P202.00	<i>Par'y</i>	None	None – Odd (3 Selections)	Comm Parity	24
P203.00	<i>Stop</i>	1 Bit	1 – 2 Bits (2 Selections)	Comm Stop Bits	24
P204.02	<i>HndSh</i>	Soft	None – Both (4 Selections)	Comm Handshake	24
P212.01	<i>Stabl</i>	Delay	Off – Delay (Toggle)	Comm Motion	24
P213.01	<i>TrTyp</i>	--1--	0 – 131 (Selection)	Print Transmission	24
P250.00	<i>RS485</i>	Disable	Enable / Disable (Toggle)	Network Option	26
P251.00	<i>Addr</i>	Disable	Disabled and 4 – 254 (Key In)	Network Address	26

<b>Parameter Number</b>	<b>Display Name</b>	<b>Default Value</b>	<b>Valid Range/ Choices</b>	<b>Parameter Description</b>	<b>Page</b>
<b>P410.--</b>	<i>Euro</i>	Disable	Enable / Disable 9991/9990 (Key In)(Toggle)	OIML Enforce	26
<b>P440.00</b>	<i>rStrc</i>	Disable	Enable / Disable (Toggle)	NTEP Enforce	26
<b>P1000.--</b>	<i>Cust. Trans</i>	--	--	Custom Transmit	26
<b>P5123.</b>	<i>TarG1</i>	0.0	0 - 999999	Bag limit	27
<b>P5133</b>	<i>TarG2</i>	0.0	0 - 999999	Total Bag Limit	27

## ***PARAMETER MAP DETAILS***

### **P110 Full Scale Value (Key in)**

Denotes the full scale capacity. This value should not exceed the rated capacity of the weighing device.

### **P111 Division Size (Selection)**

Indicates the count-by and decimal point. Pressing **[ZERO]+[TARE]** will automatically select the choice closest to 10,000 divisions without exceeding 10,000 divisions.

### **P112 Zero Track Aperture (Selection)**

Set in terms of number of divisions. Zero tracking eliminates small weight deviations at or near zero. Weight deviations within the selected window that have been stable for more than one second are tracked off, maintaining a gross or net zero condition.

The sum of weight values zeroed with auto zero tracking and **[ZERO]** cannot exceed the allowable zero range (P118).

Truck scales commonly use zero tracking to compensate for snow fall. To determine the proper setting in a counting application, divide the weight of the smallest product counted by the division size (P111). Zero Track should be set to 0 (off) for most setpoint filling operations. This prevents tracking off any product trickle at the start of a fill process.

### **P114 Stability (Selection)**

Stability is defined as weight fluctuations within an aperture that can be regarded as being a stable weight. Deviations outside this aperture are considered motion, and the motion annunciator on the front panel will light accordingly. Once the scale settles within the stability aperture, the indicator will wait one second before the indicator is considered stable.

Print operations configured as motion delayed (P114) will not send the specified data until the weight reflects a stable reading as designated by this setting. Certain setpoint operations are also considered motion delayed and will not change states until a no-motion condition exists. See individual setpoint operations in the *General Setpoint Setup* section beginning on page 34 for information on how motion is handled.

### **P116 Filter (Selection)**

Sets the indicator response time in terms of seconds. Filtering determines how quickly the indicator will respond to changing input signals. A low

filter setting speeds the response, a higher filter setting will ‘dampen’ the response.

Filtering is used to filter out weight fluctuations caused by outside sources, such as vibrations or air currents.

#### **P117 Rate (Selection)**

Specifies how often the display is updated with new data. For example, if 0.05 is selected, the controller will write data to the display every time an analog/digital conversion is made. Since the A/D converter updates every 0.05 sec, selections from 0.05 to 20.0 seconds are available. This parameter also affects the transmission rate for continuous transmit. Actual transmission intervals are dependent upon system setup.

#### **P118 Zero Range (Selection)**

Specifies how many divisions can be zeroed in terms of a **percentage** of full scale (P110). The sum of weight values zeroed through the **[ZERO]** key and auto zero tracking cannot exceed this range.

A zero range of 5% is commonly used with large tank scales to avoid accidental zeroing of a full or partially full tank.

#### **P150 Units (Toggle)**

Set default units to ‘lb’ or ‘kg’. The indicator must use the default units during calibration procedures (see *Chapter 4*). The default units are the displayed units upon indicator power-up.

#### **P151 Units Button (Toggle)**

When enabled, this parameter will allow **[UNITS]** to toggle the units between ‘lb’ and ‘kg’ (1000g). When disabled, the indicator will show only the calibration units as determined by P150.

#### **P164 Accumulate Return to Zero (Selection)**

Specifies what the gross weight must fall below before another accumulation is performed. This parameter is based on a percentage of the total capacity.

#### **P200 Baud (Selection)**

Set the desired baud rate for the communication port.

#### **P201 Data Bits (Toggle)**

Select 7 or 8 data bits for the transmission.

**P202 Parity (Selection)**

Select *Odd*, *Even* or *None* for the transmission parity.

**P203 Stop Bits (Toggle)**

Select *1* or *2* stop bits for communication port transmissions.

**P204 Comm Handshake (Selection)**

Select from *None*, *Software (Xon/Xoff)*, *Hardware (CTS/RTS)*, or *Both*.

**P210 Send (Selection)**

Transmission Send options:

Choice Number	Selection Name	Description
P210.00	<i>Off</i>	All transmissions disabled.
P210.01	<i>Press</i>	Sends transmission with <b>[PRINT]</b> key.
P210.02	<i>Cont.</i>	Sends transmissions continuously .
P210.03	<i>Cycle</i>	Send single transmission after weight is reached and motion ceases. Must return display value below 0.1% of F.S. to reset for next transmission.

**P212 Send Stability (Toggle)**

Enabling Send Stability will delay any transmissions until a no-motion condition exists.

**P213 Transmit Selection (Selection)**

Select desired print output (0 – 14). The transmission will be initiated by the selected print operation (P210).

**Choice 0 Custom Transmit:**

User-defined serial data string (see *Custom Transmit Setup* on page 28).

**Choice 1 GSE Standard Transmit:**

XXX.XX kg Gross<CR><LF>

XXX.XX kg Tare <CR><LF>

XXX.XX kg Net <CR><LF>

**Choice 2 Count:**

XXX QTY <CR/LF>

XX.X kg APW <CR><LF>

XXX.XX kg Gross<CR><LF>

XXX.XX kg Tare <CR><LF>

XXX.XX kg Net <CR><LF>

**Choice 3 (Condec Clone):**

<STX> <POL> <DATA> <L/K> <G/N> <STAT> <CR> <LF>

*Where:*

<STX> is a single control code, decimal value of 2.

<DATA> is 8 characters, 1st character is either minus sign or a space, padded with leading spaces, with an embedded decimal point.

<L/K> is a single 'L' or 'K' character to indicate lb or kg units.

<G/N> is a single 'G' or 'N' character to indicate gross or net data.

<STAT> is an 'O' (overload/underload), 'M' (motion), or space otherwise.

<CR> is a single control code (carriage return), decimal value of 13.

<LF> is a single control code (line feed), decimal value of 10.

**Choice 4:**

<STX><SignedDATA><sp><lb/kg><sp><Gross/Net/Qty><STAT><CR>

**Choice 5:**

<STX><Signed DATA><sp><lb/kg><STAT><CR>

**Choice 6:**

<STX><Signed DATA><sp><lb/kg><CR>

**Choice 7:**

<STX><Unsigned DATA><sp><CR>

**Choice 8:**

<STX><Signed  
DATA><sp><lb/kg><sp><Gros/Net/Qty><STAT><SPS><CR>

**Choice 9:**

<STX><Signed DATA><sp><lb/kg><STAT><SPS><CR>

**Choice 10:**

<STX><Signed Displayed Weight><sp><lb/kg><SPS><CR>

**Choice 11:**

<STX><Unsigned Displayed Weight><SPS><CR>

**Choice 12:**

<STX><Unsigned DATA><sp><lb/kg><sp><Gross/Net/Qty><STAT><CR>

Use choice 12 to send to a 450/455/550 remote display that is set to text mode and a <CR> terminator.

**Choice 13:**

<STX><Unsigned DATA><sp><lb/kg><sp><Gross/Net/Qty><STAT>  
<CR><LF>

**Choice 14 (Simulates NCI 3835):**

<LF>Signed DATA<CR><LF><STAT><CR><ETX>

<b>Data Block Name</b>	<b>Description</b>
<STX>	A single control code, decimal value of 2.
<ETX>	A single control code, decimal value of 3.
<POL>	A <space> for positive data or a - for negative data.
<Signed DATA>	8 characters right justified, space padded, including a decimal point and polarity sign. Polarity is a '+' or '-' to the immediate left of the most significant digit.
<Unsigned DATA>	8 characters right justified, space padded, including a decimal point.
<lb/kg>	Two characters indicating pounds or kilograms.
<Gross/Net/QTY>	Single word for gross weight, net weight or quantity.
<STAT>	An 'O' (overload/underload), 'M' (motion), or <space> otherwise
<CR>	A single control code, decimal value of 13.
<LF>	A single control code, decimal value of 10.
<sp>	ASCII Space, decimal value of 32.

### **P250 RS-485 Multi-Drop Network (Toggle)**

Enable / disable the RS-485 multi-drop network option. Requires that an RS-485 option board be installed. This option allows up to 250 RS-485 devices to be networked together in either a half duplex or full duplex wiring scheme. See the RS-485 Multi-Drop Network Setup and Operation section beginning on page for complete details on RS-485 setup and operation.

### **P251 Address (Key in)**

Specifies the address of the controller for RS-485 multi-drop communications. Allowed choices are 0 (disabled) and 4 – 254.

### **P410 Euro (Toggle)**

Enable OIML legal-for-trade restrictions (see *Chapter 5*).

### **P440 Legal For Trade Restrictions (Toggle)**

Enable NTEP legal-for-trade restrictions. See *Chapter 5* for legal-for-trade issues.

### **P1000 Custom Transmit**

A custom transmit is a user-defined string of data that can be sent to the serial port. Parameter P1000 is the beginning of the custom transmit table and must be enabled for transmit by selecting choice 0 at P213. Parameters use three bytes of memory; ASCII characters and control codes use one byte. See P60001 for available memory. The custom transmit cannot be viewed or altered from the indicator. A custom transmit *must* be entered

via the serial port. See *Custom Transmit Setup* on page 28 for details on designing and loading a custom transmit.

**P5123 Baggage Limit (target 1)**

This is the maximum limit of the bag weight. If the weight exceeds the target value, the upper display will flash and *Clear Bag* will be displayed.

**P5133 Total Baggage Limit (target 2)**

This is the maximum limit of the total bag weight. If the weight exceeds the target value, the lower display will flash. It will still accept baggage weights but the display will continue to flash until the total is cleared.



Although there are additional parameters within the setup, only the parameters listed are to be changed. Changing other parameters not specified will affect the performance of the indicator.

## CUSTOM TRANSMIT SETUP

The serial output of the ABS 4100 can be configured for a custom computer program format. The custom transmit must be designed in a computer-transmittable ASCII text file. The custom transmit can only be loaded into the indicator through the serial port. P213 must be set to 0 to select the custom transmit format for transmission.

### *ELEMENTS OF A CUSTOM TRANSMIT*

Parameters, ASCII text, and control codes are the elements of a custom transmit.

#### **Parameters**

Certain parameters related to weight, target and time/date can be sent out of the comm port. Gross Weight and Bag Limit are examples of printable parameters.

#### **ASCII Text**

ASCII text can be entered into a custom transmit to provide further detail of a transaction. “P”, “@” and “+” are examples of ASCII text.

#### **Control Codes**

You can custom transmit ASCII control codes to control a printing device. <CR> (carriage return) and <FF> (form feed) are examples of control codes.

### *WRITING A CUSTOM TRANSMIT ASCII TEXT FILE*

Any text editor may be used to construct a custom transmit (Notepad, Wordpad, etc.), but you must save the custom transmit as a text (.txt) file. Instructions can also be sent keystroke by keystroke from a communications program. To do so, ignore the display and enter the characters in the correct order. *Figure 3-1* shows a custom transmit written in Microsoft Word.

### *ACCESSING SETUP AND CLEARING EXISTING CUSTOM TRANSMIT*

Every custom transmit file must start with:

```
1999%s%s%z%p%u%e
%c%e
```



Table 3-6: ASCII / HEXADECIMAL CONVERSION CHART

										HEX	CHAR	DEC		
00	NUL	000	1A	SUB	026	34	4	052		N	078	68	h	104
01	SOH	001	1B	ESC	027	35	5	053	4F	O	079	69	i	105
02	STX	002	1C	FS	028	36	6	054	50	P	080	6A	j	106
03	ETX	003	1D	GS	029	37	7	055	51	Q	081	6B	k	107
04	EOT	004	1E	RS	030	38	8	056	52	R	082	6C	l	108
05	ENQ	005	1F	US	031	39	9	057	53	S	083	6D	m	109
06	ACK	006	20	SP	032	3A	:	058	54	T	084	6E	n	110
07	BEL	007	21	!	033	3B	;	059	55	U	085	6F	o	111
08	BS	008	22	“	034	3C	<	060	56	V	086	70	p	112
09	HT	009	23	#	035	3D	=	061	57	W	087	71	q	113
0A	LF	010	24	\$	036	3E	>	062	58	X	088	72	r	114
0B	VT	011	25	%	037	3F	?	063	59	Y	089	73	s	115
0C	FF	012	26	&	038	40	@	064	5A	Z	090	74	t	116
0D	CR	013	27	‘	039	41	A	065	5B	[	091	75	u	117
0E	SO	014	28	(	040	42	B	066	5C	\	092	76	v	118
0F	SI	015	29	)	041	43	C	067	5D	]	093	77	w	119
10	DLE	016	2A	*	042	44	D	068	5E	^	094	78	x	120
11	DC1	017	2B	+	043	45	E	069	5F	_	095	79	y	121
12	DC2	018	2C	‘	044	46	F	070	60	`	096	7A	z	122
13	DC3	019	2D	-	045	47	G	071	61	a	097	7B	{	123
14	DC4	020	2E	.	046	48	H	072	62	b	098	7C		124
15	NAK	021	2F	/	047	49	I	073	63	c	099	7D	}	125
16	SYN	022	30	0	048	4A	J	074	64	d	100	7E	~	126
17	ETB	023	31	1	049	4B	K	075	65	e	101	7F	DEL	127
18	CAN	024	32	2	050	4C	L	076	66	f	102			
19	EM	025	33	3	051	4D	M	077	67	g	103			

The following sequence enters parameters into a custom transmit: **%e**, the parameter number, **%e%e**, a format code, and then **%e%e** with no intervening spaces.

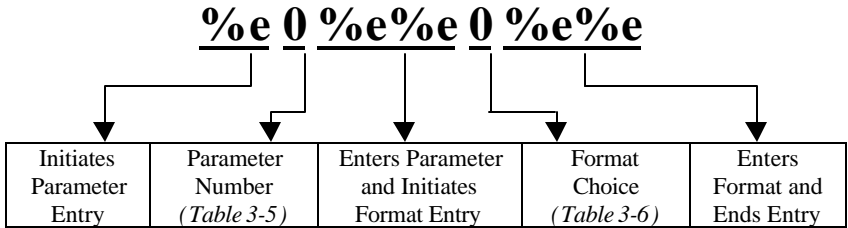

Table 3-2: Custom Transmit Parameter Selection Numbers

Parameter Name	Parameter Number	Sample Print Output
Gross Weight	0	27.45 lb Gross
Gross Total	3	101.05
Accumulation Total	9	5
Stability Status	97	Stat M
Displayed Value	98	16.34 lb Gross

The default format code for all parameters is 0. This prints all numeric data with 8 characters, right justified, left spaces filled., the units (if applicable) and the parameter name.

Table 3-3: Custom Transmit Format Codes

Choice	Sample Print Result	Description
0	“ 27.49 lb Gross”	Fixed width (8 characters), right justified, left spaces filled.
1	“000027.49 lb Gross”	Fixed width (8 characters), right justified, left zeroes filled.
2	“27.49 lb Gross”	Fixed width, left justified, right spaces filled.
3	“27.49 lb Gross”	Minimum possible width.
8	“400. lb Gross”	Print decimal point, even if data has no fractional portion.
16	“+400 lb Gross”	Print “+” for positive numbers.
32	“336.52 Gross”	Do NOT print parameter units (lb or kg).

<b>Choice</b>	<b>Sample Print Result</b>	<b>Description</b>
64	<b>“336.52 lb Gross”</b>	Print value in “default” units (as opposed to current viewed units).
128	<b>“336.52 lb”</b>	Do NOT print parameter name.

If a combination of format choices is required, add the choice numbers together and enter their sum as the format code. For example, to print the gross weight without the name (Gross) or units (lb) and to print it minimum width:

<b>Choice</b>	<b>Sample Print Result</b>	<b>Description</b>
3	<b>“336.52 lb Gross”</b>	Minimum possible width.
32	<b>“336.52 Gross”</b>	Do NOT print parameter units.
128	<b>“336.52 lb”</b>	Do NOT print parameter name.
<b>Use the sum of the desired choice selections:</b> <b>3 + 32 + 128 = <u>163</u></b>		
163	<b>“336.52”</b>	Minimum possible width. Do NOT print parameter units. Do NOT print parameter name.

### ***EXITING SETUP MODE AND SAVING CHANGES***

Each custom transmit file must end with:

**%z%c%e%e**

This exits the Setup Mode, bypasses the calibration procedure and saves the indicator configuration file.

***DISPLAY CAPTURE UTILITY***

The Display Capture Utility sends the current display information out of the comm port when the extended ASCII character represented by decimal 149 (hex: 95h) is received through the comm port. Entering a decimal 149 from a computer keyboard can be accomplished by turning on the Num Lock and holding down the ALT key while typing the desired decimal number on the keyboard keypad (for example, <Alt>149).



The Display Capture Utility must have NTEP disabled in order to function.

***EXAMPLE #1***

The scale is in the weigh mode with the gross weight displayed (for example, 15.00).

Input: The extended ASCII character represented by decimal 149 (hex: 95h) is received through the comm port.

Output: “15.00 lb      Gross      ” is sent out the com port.

***EXAMPLE #2***

The scale is in setup at P110 Full Scale.

Input: The extended ASCII character represented by decimal 149 (hex: 95h) is received through the comm port.

Output: “P110      F.S.      100.00      ” is sent out the comm port.

## GENERAL SETUP AND OPERATION

The ABS 4100 is pre-programmed for convenience. The independent setpoints are setup for baggage target and total baggage target. It is suggested that with exception to parameters 5123 and 5133 that the setpoint setup not be changed.

The target bag weight and total bag weight have a default of value of 0.0. Either target may be set through the serial port or in the setup mode.

### To set the bag limit value of 25 lbs through the serial port:

1. From your computers terminal program. Key in:  
*70 %s*  
The display will read *~Act 1= ~ 0.0*
2. Key in the desired value:  
*25 %e*  
The display will read *~ Act 1= ~ 25.0*
3. To exit back to the weight mode key in:  
*%s*

### To set the total bag limit value of 250 lbs through the serial port:

1. From your computers terminal program. Key in:  
*72 %s*  
The display will read *~Act 2= ~ 0.0*
2. Key in the desired value:  
*250 %e*  
The display will read *~ Act 2= ~ 250.0*
3. To exit back to the weight mode key in:  
*%s*

### To set the bag limit value of 25 lbs from the setup mode:

1. Access the setup mode *see page 15*:  
*P110.— — ~ F.S.= ~ 500.00*
2. Scroll with the [▲] and [▶] keys until **5123** is displayed.  
*5123*
3. Press [CLEAR TOTAL] to select parameter 5123.  
*P5123 - - ~tArg1= ~ 0.0*

4. Scroll with the [ ▲ ] and [ ► ] keys until **25** is displayed.  
**25**
5. Press [ADD TO TOTAL] to enter the new target value.  
*~tArG1= ~ 25.0*
6. Press [ZERO] twice and [ADD TO TOTAL] twice to save the change and exit to the weigh mode.

**To set the total bag limit value of 250 lbs from the setup mode:**

7. Access the setup mode *see page 15*:  
*P110.— — ~ F.S.= ~ 500.00*
8. Scroll with the [ ▲ ] and [ ► ] keys until **5133** is displayed.  
**5133**
9. Press [CLEAR TOTAL] to select parameter 5133.  
*P5133 - - ~tArG1= ~ 0.0*
10. Scroll with the [ ▲ ] and [ ► ] keys until **250** is displayed.  
**250**
11. Press [ADD TO TOTAL] to enter the new target value.  
*~tArG1= ~ 250.0*
12. Press [ZERO] twice and [ADD TO TOTAL] twice to save the change and exit to the weigh mode.

***BAGGAGE WEIGHING AND ACCUMULATION***

The top display is used to show the weight per bag. The bottom display shows the total weight and number of bags. When a bag is placed on the scale, the top display is updated. If the bag is over the target weight the top display will flash. The flashing display is only a warning to let you know the bag exceeds the limit set. It is still possible to add the bag to the total.

## RS-485 MULTI-DROP NETWORK SETUP AND OPERATION

Table 3-4 : RS-485 Network Parameters

PARAMETER SETTING	DISPLAYED NAME	DESCRIPTION	TYPE/CHOICES (*=DEFAULT)
P250.00	<i>rS485</i>	Enable or disable RS-485 network option.	Disbl*, Enabl
P251.00	<i>Addr</i>	Specifies the address of the controller for RS-485 Multi-Drop communications.	Numeric Entry: Disabled (0*) and 4 – 254

The RS-485 multi-drop network option supports both half duplex (2- wire) and full duplex (4-wire) modes of operation. The mode of operation is determined by setting jumpers 1–4 on the RS-485 option board.

Table 3-5 : RS-485 Mode of Operation

JUMPER	HALF DUPLEX	FULL DUPLEX	DESCRIPTION
1	Installed	Open	Selects half or full duplex
2	Installed	Open	
3	Installed on the endpoints of the network	Installed on the endpoints of the network	Termination resistor (R8 – 121Ω )
4	Installed	Open	Receiver disabled when transmitting (if installed)

### SETUP

The ABS 4100 controller supports address recognition, which allows a single master device to communicate with up to 250 distinct slave controllers. P250 must be enabled in order to gain access to P251. Enabling P250 by itself only causes the RTS line to become a driver enable for the RS-485 network option. Changing the P251 address to a value of 4 – 254 enables the network address recognition receive feature (i.e. networking).

### OPERATION

When P251 is enabled by choosing a valid address, the ABS 4100 will ignore all data it receives until an <STX> character is followed immediately by a character that matches the address defined by setup parameter P251. If these two conditions are met then the ABS 4100 will process all subsequent data until the end of block character, <ETX>, is

received, signaling the end of the transmission. The receive routine of the ABS 4100 then resets to look for the <STX> character again.

The *data packet* format recognized by the ABS 4100 is defined as follows:

<STX><ADDRESS><DATA><DATA><DATA><DATA>...<ETX>

Refer to *Table 3-6* on page 30 for <STX > and <ETX> ASCII codes. The address is a single byte decimal value (4 – 254). The <DATA> can be any information recognized by the ABS 4100, including direct commands – such as a %p (Print). This would direct the addressed unit to send its print transmission defined at P213 over the network.



If the received address character does not match P251 then all of the subsequent data is ignored until the next start of *packet* character, <STX>, is received.



An address of 0 at P251 will cause the ABS 4100 to process all received data.

### ***NETWORK PROTOCOL***

The protocol settings for the RS-485 network option board are the same as the protocol settings for RS-232. These settings are found starting at parameter P200.



All devices connected to the network must have matching protocol settings.



# CHAPTER 4: CALIBRATION MODE

Calibration uses the load cell(s) output signal to establish zero (no load) and span (test load) reference points. Calibration information is retained in non-volatile memory in the event of power-loss. There are two methods of accessing the Calibration Mode, exiting the Setup Mode, and entering Fast Calibration. Both approaches are discussed below. Refer to *Establishing Zero* on page 40 for complete examples of Fast Calibration methods.

## SETUP MODE CALIBRATION

You can enter the Calibration Mode after accessing the Setup Mode to view and/or change parameter settings (see *Setup Mode* on page 15).

**To access the Calibration Mode when viewing any setup parameter:**

1. From the Setup Mode, press [ZERO].  
*Enter ~ =Cal!*
2. Press [↵].  
*First ~ Zero? ~ -0.26*
3. Follow one of the specific calibration methods.
  - (a) First Zero?
  - (b) Last Zero?
  - (c) False Zero?
  - (d) Only Zero?
  - (e) Cal Reset

## FAST CALIBRATION

Fast Calibration allows calibration of the ABS 4100 scale system without accessing the Setup Mode.

**To access Fast Calibration from the Weigh Mode:**

1. From the Weigh Mode, press [CAL].  
*Fast ~ Cal!*  
*First ~ Zero? ~ -0.26*

Fast Calibration can also be accessed if the following data stream is received via the comm port:

100%*s54321%i%*e

## PERFORMING CALIBRATION

Calibration always begins by establishing a zero (no-load) reference. A complete calibration also requires establishing a span (test load) reference. This section details various methods for obtaining zero and span references.



Press **[CLR]** during calibration to back up one step in the procedure.

### *ESTABLISHING ZERO*

The ABS 4100 provides five methods for obtaining a zero (no load) calibration reference, First Zero, Last Zero, False Zero, Only Zero, and Cal Reset. Press **[CLEAR TOTAL]** to scroll through the five selections. Press **[↵]** to establish zero using the displayed method.

#### **To select a calibration method:**

1. Press **[CAL]** to display the calibration prompt.
2. Press **[CLEAR TOTAL]** to scroll through the five selections.
3. Press **[↵]** to establish zero.

#### *FIRST ZERO?*

The most common zeroing procedure, First Zero is used to establish a new zero (no load) calibration reference before proceeding to span the ABS 4100. Use this method for first-time calibration and complete recalibration.

#### **First Zero Calibration Method Example:**

1. From the Weigh Mode, press **[CAL]**.  
*Fast ~ Cal*  
*First ~ Zero? ~ -0.26*
2. Remove any load on the scale.  
*First ~ Zero? ~ -0.42*
3. Press **[↵]** to establish zero.  
*0.00*

4. Pause for motion delay.  
*Enter ~ Load ~ 0.00*
5. Place a 100lb test weight on scale.  
*Enter ~ Load ~ 99.66*
6. Enter 100.  
*100*
7. Press [**↵**] to establish span.  
*100.00*
8. Pause for motion delay.  
*Cal ~ Good? ~ 100.00*
9. Press [**↵**] to accept calibration.  
*Enter ~ =Stor*
10. Press [**↵**] to save calibration.  
*Enter ~ =End*
11. Press [**↵**] to exit calibration.  
*100.00*
12. Remove the calibration weight.  
*0.00*

*LAST ZERO?*

The Last Zero procedure allows recalibration of the weighing device using an existing test load. This is especially beneficial when checking high capacity applications such as tank weighing to minimize the task of placing and removing test weights.



Establish gross zero *before* entering setup or calibration!

**Last Zero Calibration With Weight Already Applied Example:**

1. Remove any load on the scale.  
*10.*
2. Press [**ZERO**] to zero the scale.  
*00.*
3. Apply a 10000 lb test weight to verify calibration.  
*9970.*

4. Press [CAL].  
*Fast ~ Cal*  
*First ~ Zero? ~ 9930.*
5. Press [CLEAR TOTAL].  
*Last ~ Zero? ~9930.*
6. Press [←] to use last zero.  
*Enter ~ Load? ~ 9970.*
7. Enter 10000.  
*10000*
8. Press [←] to establish span.  
*10000.*
9. Pause for motion delay.  
*Cal ~ Good? ~ 10000.*
10. Press [←] to accept calibration.  
*Enter ~ =Stor*
11. Press [←] to save calibration.  
*Enter ~ =End*
12. Press [←] to exit calibration.  
*10000.*
13. Remove the calibration weight.  
*00.*

*FALSE ZERO?*

False Zero calibrates the ABS 4100 without removing the current gross weight. This is particularly useful in tank weighing applications where it may be both time consuming and costly to completely empty the tank. This operation is achieved by establishing a false (temporary zero) zero reference. Test weights may then be added to verify calibration. The zero reference determined during the last calibration is not affected.

**False Zero Calibration Without Removing Existing Load Example:**

1. Press [CAL].  
*Fast ~ Cal*  
*First ~ Zero? ~ 5075.*
2. Press [CLEAR TOTAL] [CLEAR TOTAL].  
*False ~ Zero? ~5075.*
3. Press [↵] to establish false (temporary) zero.  
*Units ~ =lb*
4. Pause to display calibration units.  
*Enter ~ Load? ~ 00.*
5. Place a 2500lb test weight on scale.  
*Enter ~ Load? ~ 2510.*
6. Enter 2500.  
*2500*
7. Press [↵] to establish span.  
*2500.*
8. Pause for motion delay.  
*Cal ~ Good? ~ 2500.*
9. Press [↵] to accept calibration.  
*Enter ~ =Stor*
10. Press [↵] to save calibration.  
*Enter ~ =End*
11. Press [↵] to exit calibration.  
*5055.*
14. Remove the calibration weight.  
*00.*

*ONLY ZERO?*

Only Zero is used to establish a new calibration zero without affecting the span. This is useful for correcting changes to the scale's dead load, for example adding safety rails to a truck scale platform.

**Only Zero Calibration Example:**

1. From the Weigh Mode, press [**CLEAR TOTAL**].  
*Fast ~ Cal*  
*First ~ Zero? ~2640.*
2. Press [**CLEAR TOTAL**] [**CLEAR TOTAL**] [**CLEAR TOTAL**].  
*Only ~ Zero? ~ 2640.*
3. Remove any load on the scale.  
*Only ~ Zero? ~ 2620.*
4. Press [**←**] to establish zero.  
*00.*
5. Pause for motion delay.  
*Cal ~ Good? ~ 00.*
6. Press [**←**] to accept calibration.  
*Enter ~ =Stor*
7. Press [**←**] to save calibration.  
*Enter ~ =End*
8. Press [**←**] to exit calibration.  
*00.*

*CAL RESET*

Cal Reset may be necessary when an over-load or under-load condition exists, preventing the completion of the calibration process. Calibration Reset adjusts the zero and gain factors of the A/D amplifier to factory default values for maximum sensitivity.

After performing a calibration reset, a complete recalibration is required. The effects of a calibration reset do not take effect until the ABS 4100 is recalibrated and calibration information has been saved.



If **Code 02** (under-load) or **Code 03** (over-load) is displayed during calibration, press [**CLR**] to perform a calibration reset.

**Reset Calibration Gain Factors Example:**

1. Press [CAL].  
*Fast ~ Cal*  
*First ~ Zero? ~ xx.xx*
2. Remove any load on the scale.  
*First ~ Zero? ~ xx.xx*
3. Press [**↵**] to establish zero.  
*Enter ~ Load? ~ 0.00*
4. Place a 100lb test weight on scale.  
*Code03*
5. Press [ZERO].  
*First ~ Zero? ~ -0.26*
6. Remove any load on the scale.  
*First ~ Zero? ~ -0.42*
7. Press [**↵**] to establish zero.  
*0.00*
8. Pause for motion delay.  
*Enter ~ Load ~ 0.00*
9. Place a 100lb test weight on scale.  
*Enter ~ Load ~ xx.xx*
10. Enter 100.  
*100*
11. Press [**↵**] to establish span.  
*100.00*
12. Pause for motion delay.  
*Cal ~ Good? ~ 100.00*
13. Press [**↵**] to accept calibration.  
*Enter ~ =Stor*
14. Press [**↵**] to save calibration.  
*Enter ~ =End*
15. Press [**↵**] to exit calibration.  
*100.00*

- Remove the calibration weight.

**0.00**

### ***ESTABLISHING SPAN***

Once a zero reference has been established, the ABS 4100 displays **Enter ~ Load** and awaits the entry of a span (test load) value. This value may be entered before or after the test load has been applied.

If the calibration weight value was entered before applying the test weight, **Add ~ Load** is displayed indicating that the test weight should now be applied. Apply the test weight, press [**←**] and proceed to *Exiting Calibration* on page 46.

If it is necessary to repeat the calibration process, press [**ZERO**] at the **Cal ~ Good?** prompt and repeat the calibration process.

#### **Establishing span with a 100lb test weight:**

- Place a 100lb test weight on scale.

**Enter ~ Load ~ xx.xx**

- Enter 100.

**100**

- Press [**←**] to establish span.

**100.00**

- Pause for motion delay.

**Cal ~ Good? ~ 100.00**

When making a significant change to the previous calibration, or when the calibration weight is less than 5% of full scale capacity, **ReCal ~ ???** will be displayed instead of **Cal ~ Good?** In this event it is recommended that the calibration be performed a second time. Press [**←**] to recalibrate, or press [**ZERO**] to skip recalibration.

### ***EXITING CALIBRATION***

Once zero and span have been established, the newly acquired calibration information must be saved to non-volatile memory before it will be realized in the Weigh Mode.

**To exit and save calibration information:**

1. Press [**↵**] to accept calibration.  
*Enter ~ =Stor*
2. Press [**↵**] to save calibration.  
*Enter ~ =End*
3. Press [**↵**] to exit calibration.  
*100.00*

**To exit without saving calibration information:**

1. Press [**↵**] to accept calibration.  
*Enter ~ =Stor*
2. Press [**CLR**].  
*Enter ~ =Undo*
3. Press [**↵**].  
*Enter ~ =End*
4. Press [**↵**] to exit calibration.  
*99.66*



When saving calibration, parameters changed in the Setup Mode are also saved with their new selections.



## CHAPTER 5: LEGAL-FOR-TRADE

The ABS 4100 default parameter setup does not ensure compliance with legal-for-trade installations as mandated by local weights and measures authorities. This chapter contains information on NTEP and OIML regulations, sealing and audit trails, and other requirements.

Since legal-for-trade requirements may vary, you must ensure that the ABS 4100 is installed in accordance with all local regulations.

### NTEP REQUIREMENTS

The National Type Evaluation Program (NTEP) is a widely accepted weights and measures standard in the United States, with most states abiding by some or all of the NTEP requirements. A complete list of these regulations is available in the “Handbook 44” publication distributed by the National Institute of Standards and Technology (NIST). For more information, call (301) 975-3058, or visit <http://www.nist.gov>.



The ABS 4100 NTEP Certificate of Conformance (C.O.C.) # is **01-090**

In order to configure the ABS 4100 to comply with NTEP requirements, parameter P440-rstrc (*restrict*) must be enabled. This ensures the following:

- Serial data will not be received while in the Setup Mode.
- Received alpha characters will not be displayed.

Where applicable, enabling the *restrict* parameter will over-ride the current setting of other parameters.

Be sure to install the SYSTEM SERIAL NO. label on all components of the system. The NTEP inspector will use this number to certify the system.

### OIML REQUIREMENTS

The International Organization of Legal Metrology is an inter-governmental body which harmonizes the national metrology regulations of its world wide members. A list of regulation publications may be obtained from the Bureau International de Métrologie Légale (BIML) in Paris, France.

In order to configure the ABS 4100 to comply with OIML requirements, parameter P410-Euro must be enabled. Doing so will ensure the following:

- An over-load condition will result when the gross weight exceeds nine graduations over the full scale capacity.
- Full scale capacity is always referenced from the last zero calibration reference, not the last zero acquired by pressing **[ZERO]**.

Most NTEP requirements will also apply. See the *Other Requirements* section below for additional considerations.

## OTHER REQUIREMENTS

Several parameters must be considered on an individual basis as their configuration may vary with different applications. These parameters include, but are not limited to:

Parameter	Description	Comment
P110	Full Scale Capacity	Verify proper scale capacity.
P111	Division Size	Verify that the maximum allowable number of scale divisions are not exceeded.
P112	Zero Track	Verify required selection.
P114	Stability	Verify required selection.
P118	Zero Range	Verify required selection.
P212	Print Stability	Verify required selection.

## SEALING AND AUDIT TRAILS

Most legal-for-trade installations will require the ABS 4100 to be sealed. With the indicator and keypad sealed, the setup or calibration cannot be accessed without breaking a physical seal or incrementing an event counter, thus providing evidence of tampering.

The keypad is equipped with an imbedded serial number that is entered at the factory. With the program switch set in the “**NO**” position, any keypad connected to the main unit will be detected. Only a matching keypad serial number will be allowed to be used. If the serial number does not match, the unit will stop weighing and display an error message “**Code 01~SEAL AndSn**”.

A keypad with the program switch in the “**YES**” position will allow changes to be made to setup or calibration. If the keypad serial number does not match the one saved in setup, the new serial number will be stored upon saving changes.

The ABS 4100 has two types of sealing provisions, a physical seal and a three event audit trail counter. Check with your local weights and measures authority to determine your requirements.

### ***PHYSICAL SEAL***

The most common sealing method is a lead-wire seal. The ABS 4100 provides an easy means of applying this type of seal as shown in the figures below.

Before applying a wire seal, move the program switch to the 'NO' position which is located on the back side of the keypad. This will prevent access to the Setup and Calibration Modes.

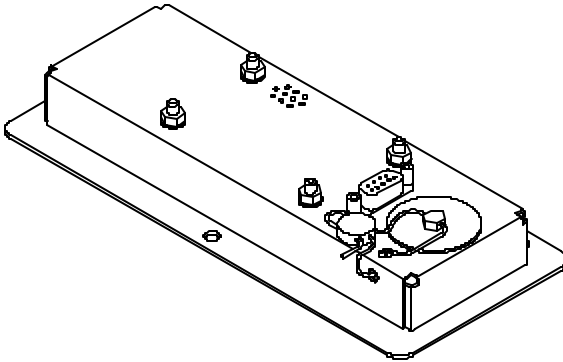

*Figure 5-1 : Physical Sealing Method for the ABS 4100 Keypad*

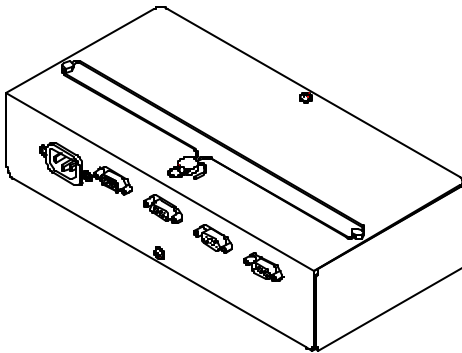

*Figure 5-2 : Physical Sealing for the ABS 4100 Main Board Enclosure*

It is also possible to tamper proof the main board enclosure by installing a physical seal as seen in *Figure 5-2*.

## ***AUDIT TRAILS***

Three separate incrementing, non-resetable audit trail parameters are used by the ABS 4100 to indicate changes to various parameters, P60201 – OIML, P60203 – Calibration, and P60204 – Setup. An audit trail counter will increment only once upon exiting the Setup Mode and saving changes regardless of how many settings were changed.

### ***OIML AUDIT TRAIL***

Changes to any of the following parameters will increment the OIML (Euro) audit trail at P60201:

- P110 – P118 (scale setup)
- P150 (default units)
- P151 (units enable)
- P410 (Euro enable)
- P440 (rStrc enable)
- Existing Calibration

### ***CALIBRATION AUDIT TRAIL***

Any changes to the existing calibration will increment the Calibration (CAL) audit trail at P60203.

### ***SETUP AUDIT TRAIL***

Changes to any of the Setup Mode parameters will increment the setup audit trail at P60204.

### ***VIEWING AUDIT TRAIL PARAMETERS***

Audit trail parameters may be viewed at any time.

### **To view audit trail parameters:**

1. Press **[ZERO] + [CLEAR TOTAL]**.  
***Setup***  
***Enter ~ Code!***
2. Press **[←]**.  
***-No- ~ Chgs!***  
***P112 ~ FS ~ xx.xx***

3. Enter 60203.  
**60203**
4. Press [**CLEAR TOTAL**] to view the selected audit trail.  
*Audit ~ Trail*  
*CAL. ~ 00001*
5. Press [**ZERO**] to return to the Weigh Mode.  
0.00



# CHAPTER 6: ABS 4100 OPTION

## RS-485 NETWORKING

The ABS 4100 controller supports address recognition for multi-drop communications. This section describes the installation of the RS-485 network option. For setup and operation information, see page 36.



The ABS 4100 contains components which could be damaged by Electrostatic Discharge (ESD) if serviced improperly. Use proper ESD precautions (wear a wrist strap connected to ground, use grounded work stations, etc.) when opening the enclosure.

High voltages may exist within the enclosure! To prevent the risk of electrical shock, **ALWAYS** unplug the ABS 4100 when opening the enclosure. Installation and servicing of the ABS 4100 should be performed by authorized and qualified service personnel only.

Never connect or disconnect option board cables while the indicator is powered. Doing so may result in circuit board damage.

### To install the RS-485 Network Option

1. Open the indicator.  
Remove the four screws from the back of the unit.  
Remove the rear cover.
2. Remove the U6 IC from its socket.
3. Remove the white wire jumper.
4. Snap the plastic spacers into the three mounting holes.
5. Gently press the option board into the socket.

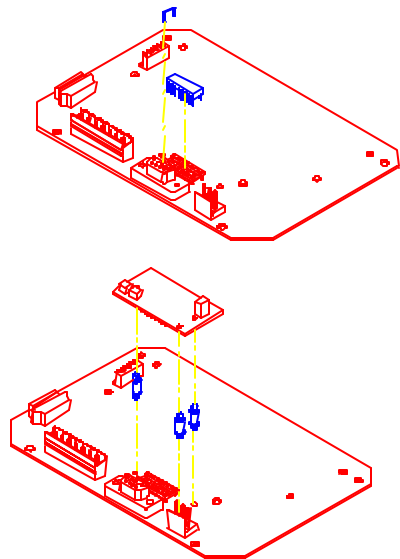

Figure 6-1 : RS-485 Installation

- Reinstall the cover. Be careful not to over tighten the screws.

**NETWORK CONNECTIONS**

Apply the supplied label designated as M350 STD near the COMM PORT connector on the outside of the main board enclosure.

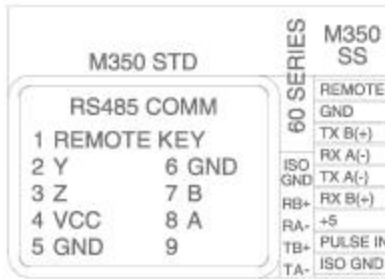

Figure 6-2: RS 485 Label

**HALF DUPLEX (2-WIRE)**

Installing jumpers 1, 2 and 4 on the RS-485 option board electrically connects pin RX B(+) to pin TX B(+), and pin RX A(-) to pin TX A(-) on the option board. This effectively provides two + and two - pin connections, enabling easy connection of network lines in parallel from device to device without having to position two wires into the same lever socket. A B(+) line from each device on the network should be connected in parallel to the next device on the network. This is also true for all A(-) lines.

The units inside the two end-points of the network loop will utilize both A(-) pin connections and both B(+) pin connections. The units at the end-points of the network will utilize only one A(-) pin connection and one B (+) pin connection.

**FULL DUPLEX (4-WIRE)**

Removing jumpers 1, 2 and 4 on the RS-485 option board requires that the transmit and receive lines be wired independently of one another. The RX B(+) and RX A(-) receive lines must be wired in parallel to the next device's RX B(+) and RX A(-) receive lines, and the TX B(+) and TX A(-) transmit lines must be wired in parallel to the next device's TX B(+) and TX A(-) transmit lines.

In order to connect network lines in parallel from device to device it is necessary to position two wires into the same lever socket. This requires that the wire used to build the network be 24AWG or smaller to allow both wires to fit into the same lever socket.

*BOTH HALF DUPLEX AND FULL DUPLEX*

The network boards on *both* end-points should install jumper 3 on the RS-485 option board to engage the 120  $\Omega$  termination resistor (R8). The boards between the two end-points should remove jumper 3 on the RS-485 option board.

The isolated ground (ISO GND) should be connected in parallel from unit to unit. A shielded twisted two pair cable is recommended throughout the network.

## Half Duplex

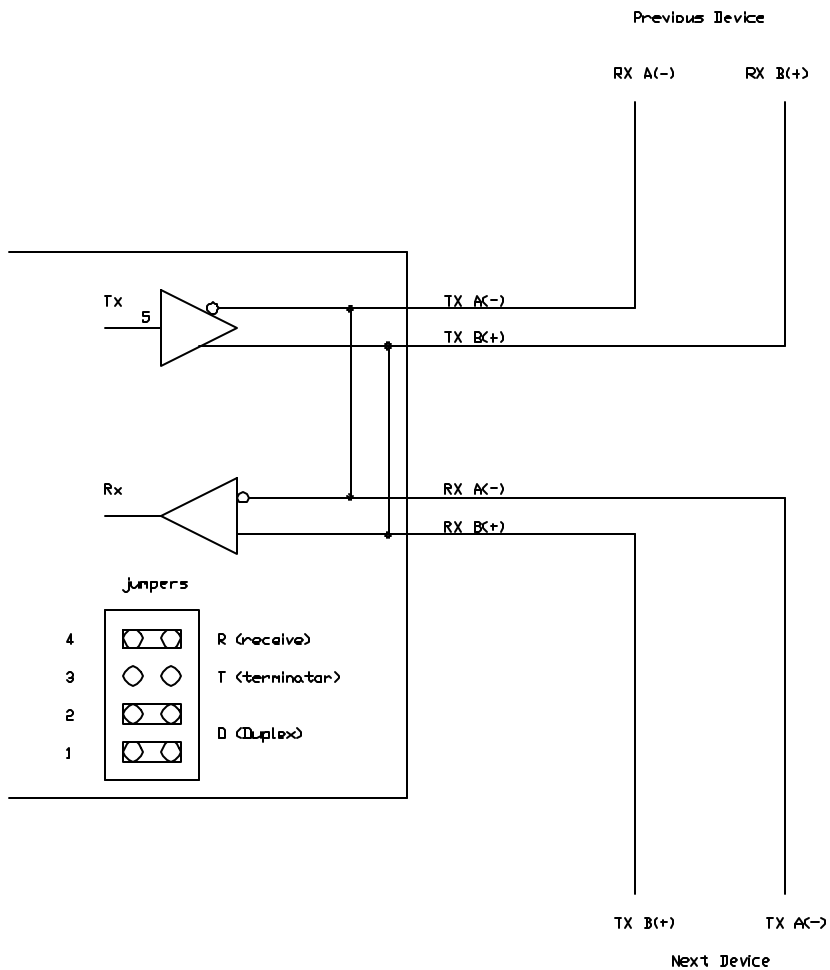

Figure 6-3: Half Duplex Wiring Schematic

Full Duplex

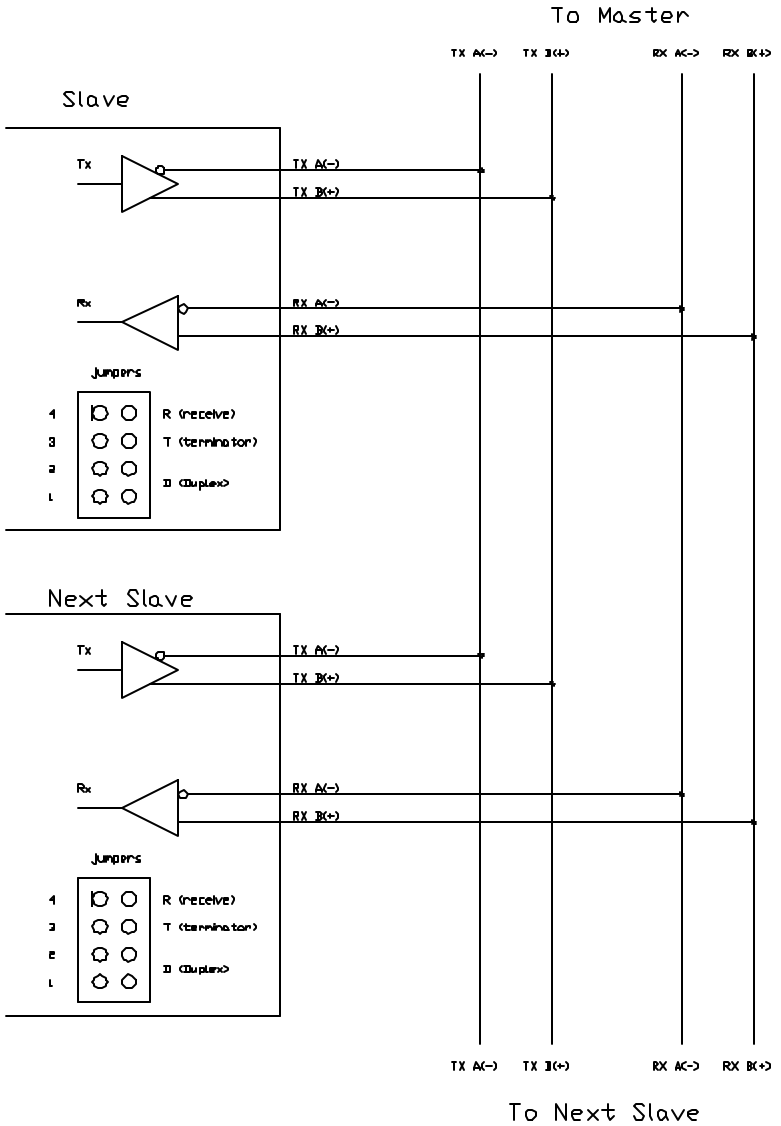

Figure 6-4: Full Duplex Wiring Schematic

# CHAPTER 7: TROUBLESHOOTING

This chapter contains error messages and information parameters, as well as information on setup parameter selections and A/D Calibration.

## ERROR MESSAGES

The ABS 4100 utilizes the following types of error messages: *Operational Errors, Setup Mode Errors, Hardware Errors, Calibration Errors, Communication Errors, and Miscellaneous Errors.*

### OPERATIONAL ERRORS

<b>Code01~ SEAL AndSn</b>	The keypad jumper is set to “ <b>NO</b> ” and the keypad serial number does not match the number stored in the main unit. Legal for trade applications.
<b>Code02</b>	Under Load. Input signal is less than negative full scale. Check load cell wiring. Verify correct capacity selection at P110.
<b>Code03</b>	Over Load. Input signal is greater than positive full scale. Use same checks as “under load” above.
<b>Funct ~ Disbl</b>	Attempted to perform a function disabled in the Setup Mode.
<b>Code 04</b>	The digits on the display have exceed the six digit display capacity
<b>Code 05</b>	Zero attempted beyond that allowed by P118.
<b>Code 08</b>	Input signal greatly exceeds the valid range. Check the load cell connection.
<b>Delay</b>	Indicates that a motion delay is in effect (zero, tare, etc.).
<b>Delay ~ Abort</b>	Acknowledges that a motion delayed function was aborted.

<i>Print ~ Abort</i>	Acknowledges that a motion delayed print request was aborted.
<i>Add ~ Load!</i>	If displayed after performing a count sample, this message indicates that a larger sample size is required.
<i>Out of ~ Range</i>	Attempted to enter a value beyond the allowable range.
<i>SPTxx ~ Error</i>	A conflict occurred with a setpoint value entry (example: target entry is less than preact). <b>The digits 'xx' represent the last two digits of the setpoint parameter in error</b> (example: <i>SPT 5 ~ Error</i> indicates a conflict at P510 <sub>5</sub> , preact 1).

### SETUP MODE ERRORS

<i>Bad ~ Code!</i>	An incorrect access code was entered.
<i>Unit ~ Seald</i>	Access to the Setup or Calibration Mode was denied. Check the internal "YES/NO" program jumper.
<i>Entry ~ Error</i>	An invalid entry was made.
<i>Need ~ Entry</i>	A numeric value was required before pressing [ <b>←</b> ].
<i>Out of ~Range</i>	The entered value exceeded the allowable range.
<i>Can't ~ Set!</i>	Attempt to change a parameter that does not allow an entry.
<i>ResGT ~ 260E3</i>	The number of divisions exceeds 260000 (see P110, P111).
<i>ResGT ~ 25E3</i>	The number of divisions exceeds 25000 (see P110, P111).
<i>ResLT ~ 100!</i>	The number of divisions is less than 100 (see P110, P111).
<i>ResLT ~ 1 !!</i>	Number of divisions is less than one (see P110, P111).

<b><i>Prtcl ~ Error</i></b>	Existing protocol is invalid. The following are not allowed: <ul style="list-style-type: none"> <li>– P201 = 7 data bits, P202 = no parity, P203 = 1 stop bit</li> <li>– P201 = 8 data bits, P202 = even parity, P203 = 2 stop bits</li> <li>– P201 = 8 data bits, P202 = odd parity, P 203 = 2 stop bits</li> </ul>
-----------------------------	--

### ***HARDWARE ERRORS***

<b><i>Code00</i></b>	An EPROM problem detected during power-up (U2).
<b><i>A-D ~ Bad! Or Code17</i></b>	Problem with A/D chip detected. Disconnect any options installed and re-power the unit. Options are connected to the same serial lines as the A/D so they may prevent it from working properly.
<b><i>Deflt ~ A-D</i></b>	Bad A/D calibration values. Recalibrate A/D (see <i>A/D Calibration Procedure</i> on page 66).
<b><i>Re- ~ Boot!</i></b>	EEPROM data could not be read. Attempting power-up reset.
<b><i>Chec ~ E2</i></b>	EEPROM data error (U4).
<b><i>Deflt ~ Setup</i></b>	An error occurred when reading setup data from the EEPROM during power-up. All parameters are set to factory default.
<b><i>Ch.XXXX</i></b>	A checksum error occurred during power-up. All annunciators are lit. The EPROM integrity test failed or is improperly seated.
<b><i>E2 ~ Full!</i></b>	The EEPROM setup exceeds the memory capacity.
<b><i>NoSpc ~ Free!</i></b>	The current setup exceeds the setup RAM capacity.

### ***CALIBRATION ERRORS***

<b><i>F.S. ~ TooHi</i></b>	The entered calibration weight will result in an over-capacity condition at full scale. Verify that the full scale (P110) and calibration weight value are correct.
----------------------------	---

<b><i>F.S. ~ TooLo</i></b>	The entered calibration weight will result in a full scale input signal less than the minimum allowed. Verify that the full scale (P110) and entered weight value are correct.
<b><i>Add ~ Load!</i></b>	The calibration weight is less than 0.1% of capacity. More weight is required.
<b><i>ReCal ~ ???</i></b>	Repeat the cal. procedure for accuracy. This prompt appears when the calibration weight is less than 5% of capacity, or when the A/D coarse gain is adjusted.
<b><i>Entry ~ Error</i></b>	An invalid entry was made.

### **COMMUNICATION ERRORS**

<b><i>Par-Er</i></b>	The selected parity (P202) does not match that of the connected device.
<b><i>Buf-Er</i></b>	The receive buffers capacity was exceeded. This indicates a handshaking problem. Check P204 and verify proper communication port connections.
<b><i>Bit-Er</i></b>	The stop bit of a received character did not occur when expected. Verify that protocol (P200 – P204) matches that of the connected device.
<b><i>TrHold</i></b>	Data transmission is inhibited due to a deasserted handshake. Press <b>[CLR]</b> to abort transmission. Check P204.

### **MISCELLANEOUS ERRORS**

<b><i>T.X.YYYY</i></b>	If catastrophic errors occur in the software, a trap error may occur and freeze the display with address information. (X = bank number and YYYY = the address of the trap error. Press any key five seconds after viewing message to reboot the unit).
------------------------	--

## **VIEWING SETUP**

While troubleshooting it may be helpful to view the setup parameter selections. This can be done using the procedure below (even with the

internal program jumper in the “NO” position). Note that accessing the Setup Mode in this manner will not permit parameter changes.

**To view the setup parameter selections:**

1. From the Weigh Mode, press [ZERO] + [CLEAR TOTAL].  
*Setup*  
*Enter ~ Code!*
2. Press [↵].  
*-No- ~ Chgs!*  
*P110.-- ~ F.S.= ~ 100.0*
3. Navigate the Setup Mode as described in *Setup Mode* on page 15.

**To exit the Setup Mode:**

1. Press [ZERO].
2. Press [↵].

## INFORMATION MODE PARAMETERS

A series of informational parameters are available beginning at P60000. These parameters may be accessed from the Setup Mode, or from the Weigh Mode as described below.

*Table 7-1* gives an explanation of each information parameter.

**To access the informational parameters:**

1. Press [ZERO] + [CLEAR TOTAL].  
*Setup*  
*Enter ~ Code!*
2. Press [ZERO] [lb/kg] [ADD TO TOTAL].  
*P60000 ~ E2Ins ~ 512*
3. Navigate the Setup Mode as described in *Setup Mode* on page 15.

As each information parameter is accessed, the parameter number is briefly displayed, followed by the parameter name, and finally the parameter value. To repeat the parameter number and name sequence, press [lb/kg]. To exit the information mode, press [ZERO].

Table 7-1 : Information Parameters

PARAMETER	NAME	DESCRIPTION
60000	<i>E2Ins</i>	Total amount of EEPROM storage.
60001	<i>E2Fre</i>	Amount of available EEPROM storage.
60100	<i>-GSE- ~ c1998</i>	Copyright statement.
60101	<i>0350P ~ 01001</i>	Firmware revision code.
60102	<i>02- 10 ~ 1998</i>	Firmware date code.
60200	<i>b sn ~ 10001</i>	Main circuit board serial number.
60201	<i>Audit ~ Trail Euro ~ 00000</i>	OIML (European) audit trail number (see <i>OIML Audit Trail</i> on page 52).
60202	<i>i sn ~ 00000</i>	ABS 4100 serial number.
60203	<i>Audit ~ Trail CAL. ~ 00000</i>	Calibration audit trail number (see <i>Calibration Audit Trail</i> on page 52).
60204	<i>Audit ~ Trail Setup ~ 00000</i>	Setup audit trail number (see <i>Setup Audit Trail</i> on page 52).
61100	<i>Load ~ Cell 0.00000</i>	Current mV/V output of the load cell.
61101	<i>Cal ~ Factr 1.00000</i>	Calibration factor for the load cell.
61102	<i>Rezro ~ Load 0.00000</i>	Amount of weight (in default units) zeroed through use of the [ZERO] key.
61103	<i>Zrtrc ~ Load 0.00000</i>	Amount of weight (in default units) zeroed by the zero track feature since [ZERO] was last pressed.
61104	<i>CZero ~ 0P</i>	Coarse zero calculated during calibration.
61105	<i>Fine ~ Zero 1738</i>	Fine zero calculated during calibration.
61106	<i>CGain ~ 50</i>	Coarse gain calculated during calibration.
61107	<i>Fine ~ Gain 1.00000</i>	Fine gain calculated during calibration.
61110	<i>Zero ~ Adj25 73741</i>	A/D compensation for coarse zero.
↓ 61112	↓ <i>Zero ~ Ad100 -21813</i>	
61117	<i>AiN1 ~ NrOff -11035</i>	A/D non-ratio-metric offset compensation.
↓ 61120	↓ <i>AiN8 ~ NrOff -14800</i>	
61121	<i>Vref ~ NrOff -12739</i>	A/D reference voltage compensation.
61200	<i>10oFF</i>	Analog option 0 – 10V Zero offset value.
61201	<i>10Gn</i>	Analog option 0 – 10V Full scale gain value.

<b>PARAMETER</b>	<b>NAME</b>	<b>DESCRIPTION</b>
61202	<i>0oFF</i>	Analog option 0 – 20mA Zero offset value.
61203	<i>0Gn</i>	Analog option 0 – 20mA Full scale gain value.
61204	<i>4oFF</i>	Analog option 4 – 20mA Zero offset value.
61205	<i>4Gn</i>	Analog option 4 – 20mA Full scale gain value.
61206	<i>Srln</i>	Analog option board serial number.
62000	<i>Dsply ~ Test 8.8.8.8.8.8.</i>	Display test. Press [ <b>↵</b> ] to illuminate all segments. Continue pressing [ <b>↵</b> ] to cycle through various patterns.
62001	<i>Spt 1 ~ Disbl</i>	Allows setpoint status to be changed by pressing [ <b>↵</b> ] while viewing this parameter. Requires that setup was entered using the access code.
62002	<i>Spt 2 ~ Disbl</i>	
62003	<i>Spt 3 ~ Disbl</i>	
62004	<i>Analg ~ 0- 10v</i>	Allows the analog output to be changed by pressing [ <b>↵</b> ]. Output will toggle through 0, 25, 50 and 100 percent while viewing this parameter. Requires that setup was entered using the access code (see <i>Analog Board Diagnostic and Test Procedures</i> on page 55).
62005	<i>Analg ~ 0-20A</i>	
62006	<i>Analg ~ 4-20A</i>	
64000	<i>Send ~ Setup</i>	Transmits all setup information out the communication port.
64100	<i>LnCnt ~ 0</i>	Received setup line count.
64101	<i>ErCnt ~ 0</i>	Received setup error count.
64102	<i>IstEr ~ None!</i>	Parameter of the first setup receive error.
65001	<i>Deflft ~ All</i>	Default All. Sets all parameters to factory default settings. Press [ <b>↵</b> ] to initiate default.
65002	<i>Deflft ~ -CAL</i>	Same as above, except calibration is retained.

## **A/D CALIBRATION PROCEDURE**

The ABS 4100 Analog-to-Digital Converter (A/D) is calibrated at the factory to ensure a stable, linear response to the load cell signal. This calibration procedure calculates critical values that are permanently stored in parameters P61110 – P61121. The A/D calibration should not be confused with the standard weight calibration. It should never be necessary to recalibrate the A/D. However, if the values stored at parameters P61110 – P61121 appear to be reset to 0.00000 and/or 1.00000, then A/D recalibration is necessary. Contact GSE Scale Systems or your local authorized GSE distributor for more information on this procedure

Your GSE Distributor is:

**PART NUMBER: 39-10-38385**