

GSE Model 350/355 IS

INTRINSICALLY SAFE INDICATOR



Technical Reference Manual

Version 1.0



Model 350/355 IS

Technical Reference Manual

Version 1.0

GSE 350IS Intrinsically Safe Technical Reference Manual

Copyright © 2004 GSE Scale Systems. All rights reserved.

Published by:

GSE Scale Systems
42860 Nine Mile Road
Novi, MI 48375
USA

Information in this *Operation Manual* is subject to change *without notice* due to correction or enhancement. The information described in this manual is solely the property of GSE. No part of this manual may be reproduced or transmitted in any form or by any means, electronic or mechanical, including photocopying and recording and sold for any monetary figure without the express written permission of GSE.

GSE Locations

GSE Scale Systems

42860 Nine Mile Road
Novi, MI 48375
U.S.A.
Phone: (800) 755-7875
www.gse-inc.com

GSE Canada, Inc.

617 East Lake Road
Airdrie, Alberta Canada T4B 2B8
Phone:(403) 948-9921
Fax: (403) 948-1449

Table of Contents

- CHAPTER 1:INTRODUCTION..... 1**
- HAZARDOUS AREA GUIDELINES 1
 - Hazard Grouping* 1
 - Duration of Hazard* 2
 - Temperature Codes* 2
 - Definitions* 4
 - Entity Evaluation Concept*..... 4
 - Entity Rating Definitions* 5
 - Entity Ratings* 5
- APPROVALS 6
- STANDARD FUNCTIONS 7
- STANDARD FEATURES..... 7
- SPECIFICATIONS 7
- DISPLAY 8
 - LED Display*..... 8
 - LCD Display*..... 9
 - Annunciators* 9
- 350 IS KEYPAD 9
 - Secondary Functions* 10
- 355 KEYPAD 11
- WEIGH MODE FUNCTIONS 12
- CHAPTER 2: INSTALLATION 13**
- SYSTEM DIAGRAMS 13
- OUTLINE DRAWINGS 13
- LOAD CELL CONNECTIONS 14
- COMMUNICATION PORT CONNECTIONS 15
- REMOTE KEY CONNECTIONS 15
- HAZARDOUS AREA OPTIONS..... 16
 - Battery Power Supply (External)*..... 16
 - AC to DC Power Supply (External)*..... 16
 - 5 Volt and 8 Volt Excitation* 17
- CHAPTER 3: CONFIGURATION 18**
- ENTERING THE SETUP MODE (MODEL 350 IS) 18
- ENTERING THE SETUP MODE (MODEL 355 IS)..... 19
- SELECTING A PARAMETER 19
- CHANGING A PARAMETER VALUE 21
 - Selection Parameters*..... 21
- KEY-IN PARAMETERS 21
- SAVING PARAMETERS 22
- FACTORY DEFAULT..... 24
- LIST OF PARAMETERS 25
 - Parameter Map Details* 27
- PRESET TRANSMIT SELECTIONS 32
- CUSTOM TRANSMIT 34
 - Elements of a Custom Transmit*..... 34
 - Writing a custom transmit ASCII text file*..... 34
 - Accessing Setup and Clearing Existing Custom Transmit*..... 34
 - Entering ASCII Text* 35
 - Entering ASCII Control Codes*..... 35
 - Parameter Selection Numbers*..... 37

<i>Exiting Setup Mode and Saving Changes</i>	38
PARTS COUNTING	38
SETPOINT SETUP	40
<i>Activation Methods (General)</i>	40
<i>Pre-acts (General)</i>	41
<i>Learn Feature (General)</i>	41
<i>Pause Feature (General)</i>	41
<i>Changing Targets from the Weigh Mode (General)</i>	42
<i>Change Target Weight Example (General)</i>	43
<i>Bargraph (General)</i>	43
PERCENTAGE CHECK-WEIGHING	46
<i>Setpoint Activation (Percentage Check-Weighing)</i>	46
<i>Changing Targets from the Weigh Mode (Percentage Check-Weighing)</i>	46
<i>Example (Percentage Check-Weighing)</i>	47
FILL	48
<i>Activation Method (Fill)</i>	48
<i>Pre-acts (Fill)</i>	48
<i>Learn Feature (Fill)</i>	49
<i>Pause Feature (Fill)</i>	49
<i>Changing Targets from the Weigh Mode (Fill)</i>	49
<i>Example (Fill)</i>	49
BATCH	49
<i>Activation Method (Batch)</i>	50
<i>Pre-acts (Batch)</i>	50
<i>Learn Feature (Batch)</i>	50
<i>Pause Feature (Batch)</i>	50
<i>Changing Targets from the Weigh Mode (Batch)</i>	50
<i>Example (Batch)</i>	51
DISCHARGE	51
<i>Activation Method (Discharge)</i>	52
<i>Pre-acts (Discharge)</i>	52
<i>Learn Feature (Discharge)</i>	52
<i>Pause Feature (Discharge)</i>	53
<i>Target Changes from the Weigh Mode (Discharge)</i>	53
<i>Example (Discharge)</i>	53
BOTH	53
<i>Activation Method (Both)</i>	54
<i>Pre-acts (Both)</i>	54
<i>Learn Feature (Both)</i>	54
<i>Pause Feature (Both)</i>	55
<i>Target Changes from the Weigh Mode (Both)</i>	55
<i>Example (Both)</i>	55
ABSOLUTE CHECK-WEIGHING	55
<i>Setpoint Activation (Absolute Check-Weighing)</i>	56
<i>Changing Targets from the Weigh Mode (Absolute Check-Weighing)</i>	56
<i>Example (Absolute Check-Weighing)</i>	57
INDEPENDENT SETPOINT OPERATION	57
<i>Setpoint Activation (Independent)</i>	58
<i>Changing Targets from the Weigh Mode (Independent)</i>	58
<i>Example (Independent)</i>	59
TARGET DEVIATION CHECK-WEIGHING	59
<i>Setpoint Activation (Target Deviation Check-Weighing)</i>	60
<i>Changing Targets from the Weigh Mode (Target Deviation Check-Weighing)</i>	60
<i>Example (Target Deviation Check-Weighing)</i>	61
BARGRAPH SETUP (LCD)	61
TIME AND DATE SETUP (MODEL 350 IS)	63

TIME AND DATE SETUP (MODEL 355 IS)	65
REMOTE KEY OPERATION	66
REMOTE SERIAL OPERATION	66
<i>Display Capture Utility</i>	67
UPGRADE INDICATOR FIRMWARE	67
<i>Prepare for upgrade</i>	68
<i>Load Flash File</i>	68
CHAPTER 4: CALIBRATION	69
SETUP MODE CALIBRATION	69
FAST CALIBRATION	69
PERFORMING CALIBRATION	69
ESTABLISHING ZERO	70
<i>First Zero</i>	70
<i>Last Zero</i>	72
<i>False Zero</i>	74
<i>Only Zero</i>	76
<i>Reset Calibration</i>	77
ESTABLISHING A SPAN	79
EXITING CALIBRATION	80
CHAPTER 5: LEGAL FOR TRADE.....	82
NTEP REQUIREMENTS	82
OMIL REQUIREMENTS	82
OTHER REQUIREMENTS	83
SEALING AND AUDIT TRAILS	83
<i>Physical Seal</i>	84
<i>Audit Trails</i>	84
CHAPTER 7: TROUBLESHOOTING.....	86
ERROR MESSAGES	86
<i>Operational Errors</i>	86
<i>Setup Mode Errors</i>	87
<i>Hardware Errors</i>	87
<i>Calibration Errors</i>	88
<i>Communication Errors</i>	88
<i>Miscellaneous Errors</i>	88
VIEWING SETUP	89
INFORMATION MODE PARAMETERS	89
A/D CALIBRATION PROCEDURE	91

CHAPTER 1:INTRODUCTION

Thank you for selecting the GSE Model 350/355 Intrinsically Safe Indicator. The Model 350 and Model 355 IS continue the GSE tradition of *Excellence in Weighing*. A properly installed and maintained Model 350 or Model 355 IS will provide many years of reliable, accurate performance.

The chapters of this manual focus on various aspects of the Model 350/355 IS:

Chapter 1: Introduction	Hazardous Area Guidelines, Features and Specifications.
Chapter 2: Installation	Installation of Indicator and Options.
Chapter 3: Configuration	Setup the 350/355 IS to a specific application.
Chapter 4: Operation	Using the Model 350/355 IS.
Chapter 5: Calibration	Calibrate the indicator to a scale.
Chapter 6: Troubleshooting	Troubleshooting help and error messages.

Hazardous Area Guidelines

The GSE Models 350IS and 355IS instruments are approved by FM Approvals as intrinsically safe for use in hazardous areas. An intrinsically safe device has been proven through calculation and testing that it cannot produce enough electric or thermal energy under normal or fault conditions to cause ignition of flammable material present in the atmosphere. The hazardous area is defined in terms of how long the hazard is present, how easily it is ignited, and what maximum temperature can be present.

HAZARD GROUPING

	Gas/Dust/Fiber	US (NEC 505) IEC/CENELEC	US (NEC500)
Gases	Acetylene	Group IIC	Class I/Group A
	Hydrogen	(Group IIB + H ₂)	Class I/Group B
	Ethylene	Group IIB	Class I/Group C
	Propane	Group IIA	Class I/Group D
	Methane	Group I *	Mining *
Dusts	Metal Dust	None	Class II/Group E
	Coal Dust	None	Class II/Group F
	Grain Dust	None	Class II/Group G
	Fibers	None	Class III

- Not within scope of NEC

DURATION OF HAZARD

	Flammable material present continuously	Flammable material present intermittently	Flammable material present abnormally
IEC/CENELEC	Zone 0	Zone 1	Zone 2
US (NEC 505)	Zone 0	Zone 1	Zone 2
US (NEC 500)	Division 1		Division 2

TEMPERATURE CODES

Max. Surface Temp.	US (NEC 505) IEC/CENELEC	US (NEC 500)
450°C	T1	T1
300°C	T2	T2
280°C		T2A
260°C		T2B
230°C		T2C
215°C		T2D
200°C	T3	T3
180°C		T3A
165°C		T3B
160°C		T3C
135°C	T4	T4
120°C		T4A
100°C	T5	T5
85°C	T6	T6

Class I, Division 1, Groups A, B, C & D

Class I, Division 1 locations are those in which hazardous concentrations of flammable gases or vapors exist continuously, intermittently or periodically under normal operating conditions. Electrical equipment for use in such locations may be “explosion proof,” “intrinsically safe,” “purged” or otherwise protected to meet the intent of Articles 500 of the National Electrical Code®.

Explosion proof protection consists of equipment designed to be capable of containing an internal explosion of a specified flammable vapor-air mixture. In addition, the equipment must operate at a safe temperature with respect to the surrounding atmosphere.

Intrinsically safe electrical equipment and associated wiring are incapable of releasing sufficient electrical or thermal energy to cause ignition of a specific hazardous material under “normal” or “fault” operating conditions. Normal operation assumes maximum supply voltage and rated environmental extremes; fault conditions assume any single or dual independent electrical faults plus field wiring open, shorts or connections to ground. Equipment rated as intrinsically safe is recognized by Article 500 as safe for use in hazardous locations without special enclosures or physical protection that would otherwise be required.

Purged systems have fresh air or an inert gas under positive pressure to exclude ignitable quantities of flammables from the electrical equipment enclosure.

Equipment Approved for Division 1 locations shall be permitted in Division 2 locations of the same class, group and temperature class.

Class I, Division 2, Groups A, B, C & D

Class I, Division 2 locations are those in which hazardous concentrations of flammables exist only under unlikely conditions of operation. As such, equipment and associated wiring which are incapable of releasing sufficient electrical and thermal energy to ignite flammable gases or vapors under “normal” operation and environmental conditions are safe to use in Class I, Division 2 locations.

Class I, Zone 0, Groups IIC, IIB & IIA

A Class I, Zone 0 location is a location (1) in which ignitable concentrations of flammable gases or vapors are present continuously; or (2) in which ignitable concentrations of flammable gases or vapors are present for long periods of time. Electrical apparatus for use in such locations may be type of protection “ia” Intrinsic Safety.

Class I, Zone 1, Groups IIC, IIB & IIA

A Class I, Zone 1 location is a location (1) in which ignitable concentrations of flammable gases or vapors are likely to exist under normal operating conditions; or (2) in which ignitable concentrations of flammable gases or vapors may exist frequently because of repair or maintenance operations or because of leakage; or (3) in which equipment is operated or processes are carried on, of such a nature that equipment breakdown or faulty operations could result in the release of ignitable concentrations of flammable gases or vapors and also cause simultaneous failure of electrical equipment in a mode to cause the electrical equipment to become a source of ignition; or (4) that is adjacent to a Class I, Zone 0 location from which ignitable concentrations of vapors could be communicated, unless communication is prevented by adequate positive-pressure ventilation from a source of clean air and effective safeguards against ventilation failure are provided. Electrical apparatus for use in such locations may be type of protection “d” Flameproof, “e” Increased Safety, “ib” Intrinsic Safety, “m” Encapsulation, “o” Oil Immersion, “p” Pressurized or “q” Powder-Filled.

Note: Electrical apparatus Approved for use in Class I, Zone 0 locations shall be permitted in Class I, Zone 1 locations of the same gas group and temperature class.

Class I, Zone 2, Groups IIC, IIB & IIA

A Class I, Zone 2 location is a location (1) in which ignitable concentrations of flammable gases or vapors are not likely to occur in normal operation and if they do occur will exist only for a short period; or (2) in which volatile flammable liquids, flammable gases or flammable vapors are handled, processed or used, but in which the liquids, gases or vapors normally are confined within closed containers or closed systems from which they can escape only as a result of accidental rupture or breakdown of the containers or system or as the result of the abnormal operation of the equipment with which the liquids or gases are handled, processed or used; or (3) in which ignitable concentrations of flammable gases or vapors normally are prevented by positive mechanical ventilation, but which may become hazardous as the result of failure or abnormal operation of the ventilation equipment; or (4) that is adjacent to a Class I, Zone 1 location, from which ignitable concentrations of flammable gases or vapors could be communicated, unless such communication is prevented by adequate positive-pressure ventilation from a source of clean air and effective safeguards against ventilation failure are provided. Electrical apparatus for use in such locations may be type of protection “nA” Non-Sparking, “nC” Protected contacts, “nR” Restricted Breathing or “p” Pressurized.

Note: Electrical apparatus Approved for use in Class I, Zone 0 or Zone 1 locations shall be permitted in Class I, Zone 2 locations of the same gas group and temperature class.

Class II, Divisions 1 & 2, Groups E, F & G

Electrical equipment suitable for use in Class II locations, as defined by the National Electrical Code[®], is constructed to exclude ignitable amounts of dust from the equipment enclosure. Approved equipment of this type has also been evaluated to assure that hazardous surface temperatures do not exist. Equipment listed as

suitable for Class II locations is “dust-ignitionproof” or otherwise designed to meet the intent of Articles 500 and 502 of the National Electrical Code®.

Class III, Divisions 1 & 2

Class III locations are those which are hazardous because of the presence of ignitable fibers or flyings. Equipment listed for installation in Class III locations is designed to exclude the fibers and flyings from the equipment enclosure and to function without developing excessive surface temperatures.

DEFINITIONS

Associated Apparatus — Apparatus, including Category ia and ib apparatus, in which the circuits are not necessarily intrinsically safe themselves, but which affect the energy in the intrinsically safe circuits and are relied upon to maintain intrinsic safety. Associated electrical apparatus may be either:

- a) Electrical apparatus that has an alternative type of protection for use in the appropriate potentially flammable atmosphere; or
- b) Electrical apparatus not so protected and thus not suitable for use in a potentially flammable atmosphere.

Control Drawing — A drawing or other document provided by the manufacturer of the intrinsically safe or associated apparatus that details the allowed interconnections to other circuits or apparatus. If the intrinsically safe or associated apparatus is investigated under the entity concept, the control drawing will include the applicable electrical parameters to permit selection of apparatus for interconnection.

Entity Evaluation Concept — A method used to determine acceptable combinations of intrinsically safe apparatus and connected associated apparatus that have not been investigated in such combination.

Hazardous (Classification) Location: A location in which fire or explosion hazards may exist due to an explosive atmosphere of flammable gases or vapors, flammable liquids, combustible dust, or easily ignitable fibers or flyings.

Intrinsically Safe Circuit — A circuit in which any spark or thermal effect, produced either normally or in specified fault conditions, is incapable, under the test conditions prescribed in this standard, of causing ignition of a mixture of flammable or combustible material in air in the mixture’s most easily ignited concentration.

Nonincendive Circuit - A circuit, other than field wiring, in which any arc or thermal effect produced under intended operating conditions of the equipment is not capable, under specified test conditions, of igniting the flammable gas-air, vapor-air, or dust-air mixture.

ENTITY EVALUATION CONCEPT

The Model 350IS and 355IS indicators have been approved under the entity evaluation concept, which allows the interconnection of intrinsically safe devices in hazardous areas even though these devices were not specifically approved in this combination. This means that not only can the instrument be used with GSE FM Approved loadcells and peripherals, but they can also be used with any manufacturer’s FM Approved loadcells and peripherals provided that they have matching entity ratings and are approved for the appropriate hazardous area.

The criteria for interconnection is that the maximum input voltage and current, which intrinsically safe apparatus can receive and remain intrinsically safe, considering faults, must be equal to or greater than the maximum output voltage and current levels which can be delivered by the associated apparatus, considering faults and applicable factors. In addition, the maximum internal capacitance and inductance of the intrinsically safe apparatus, including interconnecting wiring, must be less than or equal to the maximum allowed capacitance and inductance which can be safely connected to the associated apparatus. If these

criteria are met, then the combination may be connected and remain intrinsically safe. If the specific capacitance and inductance ratings of the wiring are unknown, use a capacitance of 60pF/ft and an inductance of 0.2uH/ft.

When connecting a Model 350IS or 355IS to another intrinsically safe device, the entity ratings must be compared and satisfy the conditions shown in the following table.

350IS/355IS Indicator	Condition	Intrinsically Safe Device
Voc	<=	Vmax or Ui
Isc	<=	Imax or Ii
Ca	>=	Ci + cable capacitance
La	>=	Li + cable inductance
Po	<=	Pi

ENTITY RATING DEFINITIONS

Voc or Uo – the maximum open circuit voltage that may be present at the specified terminals

Isc or Io – the maximum short circuit current that may be present at the specified terminals

Ca or Co - the maximum capacitance that may be connected to the specified terminals

La or Lo - the maximum inductance that may be connected to the specified terminals

Po - the maximum output power from the specified terminals

Lo/Ro – inductance to resistance ratio that indicates the maximum inductance per ohm of resistance that can be connected to the specified terminals

Vmax or Ui – the maximum voltage that may be connected to the specified terminals

Imax or Ii - the maximum current that may be connected to the specified terminals

Ci – the capacitance present at the specified terminals

Li – the inductance present at the specified terminals

Pi – the maximum power that may be supplied to the specified terminals

Li/Ri – the maximum internal inductance to resistance ratio at the specified terminals

ENTITY RATINGS

Terminal	Description	Voc	Isc	Po	Ca	La	Group
J10	Loadcell (5V EXC)	7V	400mA	700mW	8.3uF	198mH	A-G, IIC-IIA
J10	Loadcell (8V EXC)	14 V	400mA	1.4W	4.6uF	945.2uH	C-G, IIB-IIA
J8	COMM 1&2	7V	50mA	87.5mW	15.4uF	13.7mH	A-G, IIC-IIA
J11	Remote Keys	7V	62mA	109mW	15.4uF	9mH	A-G, IIC-IIA
J5	Remote Display	7V	50mA	87.5mW	15.7uF	13.7mH	A-G, IIC-IIA

Approvals

The Model 350IS and 355IS indicators and options have been approved for the following hazardous areas:

Indicator/Option	Approval
M350IS/M355IS (5V Excitation) 20H350-00010 20H350-00020 20H350-00030 20H355-00010 20H355-00020 20H355-00030	Intrinsically Safe for Class I-III, Division 1, Group A-G Intrinsically Safe for Class I, Zone 0, Group IIC-IIA Nonincendive for Class I, Division 2, Group A-D Nonincendive for Class I, Zone 2, Group IIC-IIA Suitable for use in Class II-III, Division 2, Group F-G Temperature code T4 (Ta=50°C)
M350IS/M355IS (8V Excitation) 20H350-00011 20H350-00021 20H350-00031 20H355-00011 20H355-00021 20H355-00031	Intrinsically Safe for Class I-III, Division 1, Group C-G Intrinsically Safe for Class I, Zone 0, Group IIB-IIA Nonincendive for Class I, Division 2, Group A-D Nonincendive for Class I, Zone 2, Group IIC-IIA Suitable for use in Class II-III, Division 2, Group F-G Temperature code T4 (Ta=50°C)
Battery Power Supply Option 24H3502-201C0	Intrinsically Safe for Class I-III, Division 1, Group A-G Intrinsically Safe for Class I, Zone 0, Group IIC-IIA Nonincendive for Class I, Division 2, Group A-D Nonincendive for Class I, Zone 2, Group IIC-IIA Suitable for use in Class II-III, Division 2, Group F-G Temperature code T2D (Ta=50°C)
AC-DC Power Supply Option 24H3501-200C0 (single output used)	Associated Apparatus with Intrinsically Safe Connections for Class I-III, Division 1, Group A-G Encapsulated for use in Class I, Zone 1, AEx m [ib] Group IIC-IIA Nonincendive for Class I, Division 2, Group A-D Nonincendive for Class I, Zone 2, Group IIC-IIA Suitable for use in Class II-III, Division 2, Group F-G Suitable for use in Class I-III, Division 1, Group A-G* Temperature code T4 (Ta=50°C) * When installed in a Class I-III, Division 1, Group A-G location, conduit must be used on the AC supply cable.
AC-DC Power Supply Option 24H3501-200C0 (dual outputs used)	Associated Apparatus with Intrinsically Safe Connections for Class I-III, Division 1, Group C-G * Encapsulated for use in Class I, Zone 0, Group IIB-IIA * Nonincendive for Class I, Division 2, Group C-D Nonincendive for Class I, Zone 2, Group IIB-IIA Suitable for use in Class II-III, Division 2, Group F-G Suitable for use in Class I-III, Division 1, Group C-G* Temperature code T4 (Ta=50°C) * When installed in a Class I-III, Division 1, Group C-G location, conduit must be used on the AC supply cable.

Standard Functions

The Model 350 and 355 IS include built-in functions that you can enable through the Indicator Setup. Refer to *Chapter 3: Configuration* for information on the setup and operation of the following standard functions:

- Check-weighing
- Parts counting
- Remote key operation
- Selectable, built-in data transmission formats
- Custom data transmissions

Standard Features

- Three display choices (LCD, LCD backlit and LED).
- LED model uses low current high efficiency display digits and annunciators to save battery life and adds brightness to dimly lit areas.
- Real time clock with battery backed time and date.
- Two RS-232 communication ports.
- Model 355 has a numeric keypad
- Stainless Steel washdown enclosure
- Up to (4) 350 ohm loadcells
- Easily update firmware via the RS-232 port

Specifications

PERFORMANCE

Full Scale (F.S.)	Selectable 0 to 999,999
Resolution	20-bit A/D converter, 100,000d displayed, 1,000,000d internal
A/D Conversion	60 Hz
Zero Track	0 – 100% of Full Scale
Operating Temperature	-10°C to +40°C
Units of Measure	lb, kg, oz, g, lb-oz

ELECTRICAL

Power Requirement	Input (J14): 5.1V – 12V DC
Excitation Voltage	5 VDC or 8V DC
Excitation Current	57 mA max. (5V EXC) or 91mA max. (8V EXC) / (4) 350Ω bridge
F.S. Signal Input	0.1 mV/V min – 10 mV/V max
Signal Connection	4 lead or 6 lead with sense

PROCESS CONTROL

Remote Input	2 momentary contact closure (100ms minimum) TARE, PRINT, ZERO
--------------	--

ENCLOSURE

Shipping Weight	7 lb (3 kg)
Material	304 Stainless Steel, NEMA 4X/IP66 Design
Mounting	2 swivel brackets are available for battery or AC operation

DISPLAY

LED	6-digit weight display, 0.8" (22mm) height 12 LED annunciators for operational status
LCD	6-digit weight display, 1.0" (25.4mm) height 12 LCD annunciators for operational status. Built in LCD status bargraph. Also available with backlight

COMMUNICATION

RS-232	(2) RS232 communication ports, 1 with hardware handshaking
--------	--

KEYPAD

350 IS	Five key, durable elastomeric (rubber)
355 IS	22 key, full numeric, durable elastomeric (rubber)

SAFE AREA OPTIONS

Battery Charger	Charges completely discharged battery option in 3.5 hours Universal AC input 85-265VAC, 50/60 Hz
-----------------	---

HAZARDOUS AREA OPTIONS

Battery	Stainless steel enclosure, mounts to indicator swivel bracket. 200 hours continuous use with LCD display + 1 loadcell, and 100 hours continuous use with LED display + 1 loadcell. Charge time 3.5 hours with battery charger option.
AC to DC Power Supply	Stainless steel enclosure. Powers up to 2 indicators (2 indicators can only be powered in Groups C-G hazardous area). Wall mount. Universal AC input 90-250VAC, 50/60 Hz.
Power Extension Cable	Allows the AC-DC power supply to be mounted away from the indicator. 25 feet and 50 feet lengths available.

Display

The Model 350 and 355 intrinsically safe indicators are available with a six digit, 7-segment red LED display, six digit, 7-segment black LCD display or 7-segment backlit LCD display. The Model 350 and 355 IS will display alphanumeric data, but due to the nature of 7-segment LEDs/LCD and the limitation of six digits, some information is abbreviated.

All segments and annunciators are illuminated for a brief display test upon power up. The current gross weight is then displayed in default units.

LED DISPLAY

The LED display is a six digit, 7-segment bright red LED screen with 12 annunciators to show weight and status information. The SP1, SP2, and SP3 annunciators are red, green, and yellow. Also there is an annunciator for a third unit under kg. Place the third unit label above the third annunciator (the third unit is available on both the LED and LCD displays). See *page 28* for third unit setup.

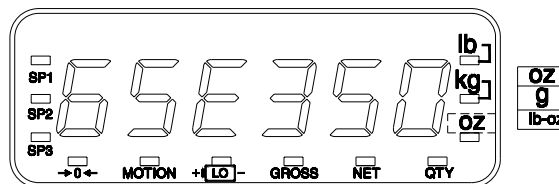

Figure 1: Model 350/355 IS LED Display

LCD DISPLAY

The LCD display is a six digit, 7-segment black LCD screen with 12 annunciators and a bargraph to show the operational status.

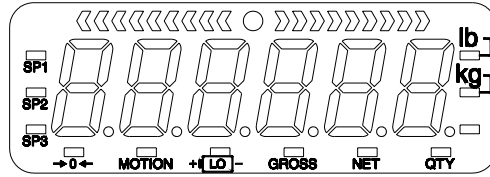

Figure 2: Model 350/355 IS LCD Display

ANNUNCIATORS

Annunciators provide mode and status information. When illuminated, they indicate the following conditions:

SP1	Setpoint #1 activated (relay 1 closed).
SP2	Setpoint #2 activated (relay 2 closed).
SP3	Setpoint #3 activated (relay 3 closed).
→0←	Displayed weight is at center-of-zero ($\pm \frac{1}{4}$ display graduation).
MOTION	Scale is in motion. Motion inhibited transmits and motion inhibited setpoint activation will be delayed until motion ceases.
LO	Lights when the battery reaches a low tolerance.
GROSS	Displayed value represents the current gross weight.
NET	Displayed value represents the current net weight.
QTY	Displayed value represents the current piece quantity (Count).
lb	The displayed value is represented in pounds.
kg	The displayed value is represented in kilograms.
Oz, lb oz, g	The displayed value is represented in either ounces, pound ounces or grams.

350 IS KEYPAD

The Model 350 IS offers a sealed 5-button elastomer keypad is used for operator input. Each key is assigned two distinct functions. Various key combinations are also used. Each key has secondary functions; allowing an operator to enter target values, perform piece samples, access setup parameters, etc.

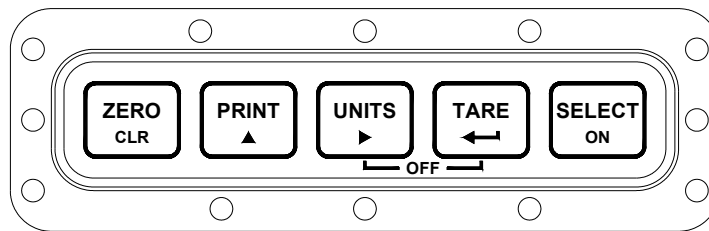





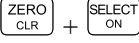

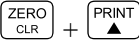



Figure 3: Model 350 IS Keypad

SECONDARY FUNCTIONS

The Model 350 IS keypad performs different functions in the Weigh Mode, the Setup Mode, and the Calibration Mode. Secondary functions for each key allow you to perform additional tasks.

Key Press	WEIGH MODE	Count Mode	Setup Mode
	Performs a gross zero function and/or clears an entry in progress. Hold this key on power-up to turn on the display regardless of P420.	Performs a quantity zero function and/or clears an entry in progress.	Exits the Setup Mode and/or answers "NO" to query prompts and/or clears an entry in progress.
	Performs a print function and/or 'scrolls' through digits during setpoint entry.	Performs a print function and/or 'scrolls' through digits during setpoint entry.	'Scrolls' through digits during data entry.
	Toggles between 'lb' and 'kg' and/or advances cursor to next entry position.	Toggles through standard sample sizes and/or begins a new sample entry.	Advances cursor to next entry position and/or cycles prompts.
	Performs an auto-tare function (if enabled) and/or accepts an entry in progress.	Performs an auto-tare function and requests a piece sample and/or accepts an entry in progress.	Accepts an entry in progress and/or 'scrolls' through parameter sub-set selections and/or answers 'YES' to query prompts.
	Toggles between display modes and/or restores power to the indicator (if auto-shutoff enabled).	Toggles between display modes and/or restores power to the indicator (if auto-shutoff enabled).	Advances to the next setup parameter.
	Access Setup Mode.	Access Setup Mode.	No function.
	No function.	No function.	Return to the previous setup parameter.
	Absolute clear – clears an entry in progress and/or clears the value of a parameter.	No function.	Clears any entry in progress.
	Backspace – erases the right-most digit during data entry.	Backspace – erases the right-most digit during sample entry.	Backspace – erases right-most digit during data entry.
	Turn off indicator by holding key for approximately 1 second.	Turn off indicator by holding key for approximately 1 second.	Turn off indicator by holding key for approximately 1 second.
	Reverse character scroll during data entry.	Reverse character scroll during sample entry.	Reverse character scroll during data entry.

355 Keypad

The Model 355 IS keypad performs different functions in the Weigh Mode, the Setup Mode, and the Calibration Mode. The number keys make entering a tare value or average piece weight easier.

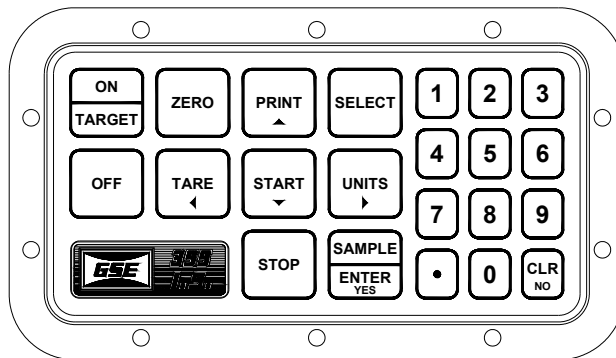













Figure 4: Model 355 IS Keypad

Key Press	WEIGH MODE	Count Mode	Setup Mode
ZERO	Performs a gross zero function and/or clears an entry in progress.	Performs a quantity zero function and/or clears an entry in progress.	Exits the Setup Mode and/or answers “NO” to query prompts and/or clears an entry in progress.
PRINT ▲	Performs a print function and/or ‘scrolls’ through digits during setpoint entry.	Performs a print function and/or ‘scrolls’ through digits during setpoint entry.	‘Scrolls’ through digits during data entry.
UNITS ►	Toggles between ‘lb’ and ‘kg’ and/or advances cursor to next entry position.	Toggles through standard sample sizes and/or begins a new sample entry.	Advances cursor to next entry position and/or cycles prompts.
TARE ◀	Performs an auto-tare function (if enabled) and/or accepts an entry in progress. If the tare weight is known, key in the value and press  .	Performs an auto-tare function and/or accepts an entry in progress.	Accepts an entry in progress and/or ‘scrolls’ through parameter sub-set selections and/or answers ‘YES’ to query prompts.
SELECT	Toggles between display modes and/or restores power to the indicator (if auto-shutoff enabled).	Toggles between display modes and/or restores power to the indicator (if auto-shutoff enabled).	Advances to the next setup parameter.
SAMPLE ENTER	Performs a sample. If a number is keyed in before hand, it will be used as the sample size. Accepts an entry.	Performs a sample. If a number is keyed in before hand, it will be used as the sample size.	Accepts an entry.
CLR NO	Clears an entry in progress. Hold this key on power-up to turn on the display regardless of P420.	Performs a quantity zero function and/or clears an entry in progress.	Exits the Setup Mode and/or answers “NO” to query prompts and/or clears an entry in progress.
START ▼	If setpoints are enabled, causes a process to start or resume. See parameter 5003 on page 31 for details on enabling the  function.	If setpoints are enabled, causes a process to start or resume. See parameter 5003 on page 31 for details on enabling the  function.	No function





Key Press	WEIGH MODE	Count Mode	Setup Mode
	If setpoints are enabled, causes a pause. Press  again to abort the process. See parameter 5002 on page 31 for details on enabling the stop function.	If setpoints are enabled, causes a pause. Press  again to abort the process. See parameter 5002 on page 31 for details on enabling the stop function.	No function
	Wake up the indicator if in sleep mode. Turn on the indicator if power is off. Access the target entry mode. See parameter 5000 on page 31 for details on enabling the target function.	Wake up the indicator if in sleep mode. Turn on the indicator if power is off. Access the target entry mode. See parameter 5000 on page 31 for details on enabling the target function.	No function
	Turn off indicator by holding key for approximately 1 second.	Turn off indicator by holding key for approximately 1 second.	Turn off indicator by holding key for approximately 1 second.



When the 355 IS keypad is installed with a new main board, the 355 IS keypad must be initialized. Hold down the  key while power is applied. If the keypad was enabled, the display will show “EntHld”. To reestablish the keypad as a 350 IS, hold down the  key of the 350 IS keypad while power is applied by pressing the  key.

Weigh Mode Functions

The Model 350 and 355 IS keypads have five primary Weigh Mode functions:

-  Performs a gross zero and selects the gross mode.
-  Initiates data transmission out the communication port.
-  Toggles the units of measure between lb, kg, g, lb oz, oz.
-  Tares any displayed weight and selects the net mode.
-  Toggles the display between GROSS, NET, QUANTITY and setpoint TARGETS (if enabled).

CHAPTER 2: INSTALLATION

System Diagrams

The control drawing details the allowed interconnections between the M350IS/M355IS indicators, their options, and other possible devices. The drawing also shows the entity ratings of the indicators to allow easy selection of other devices approved under the entity concept. See the system diagrams included with the 350 IS or 355 IS indicator.

Outline Drawings

The outline drawings provide measurements needed for indicator installation.

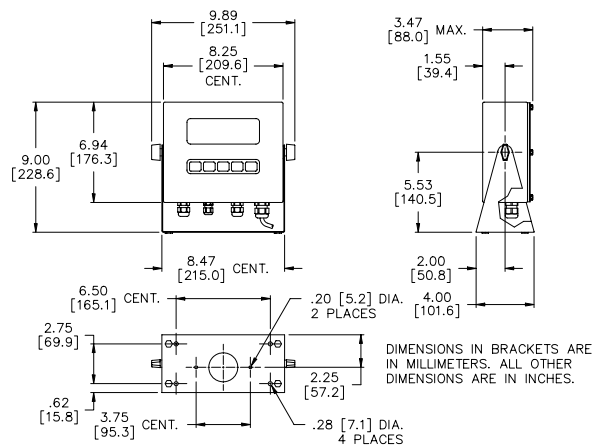

Figure 5: Model 350 with Standard Swivel Bracket

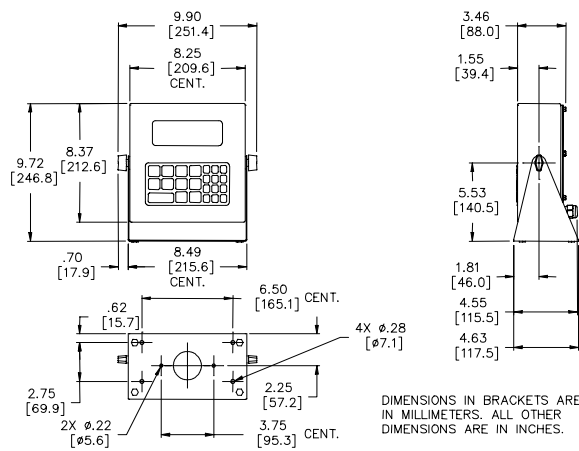

Figure 6: Model 355 IS with Standard Swivel Bracket

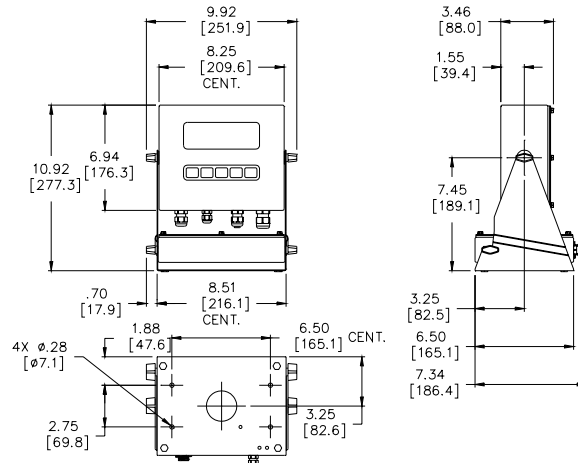

Figure 7: Model 350 IS with Battery Swivel Bracket

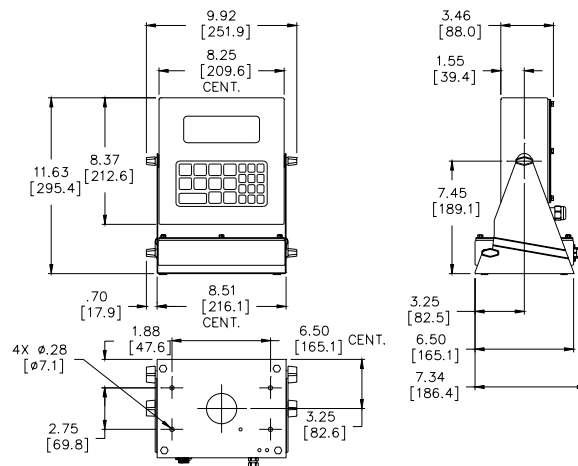

Figure 8: Model 355 IS with Battery Swivel Bracket

Load Cell Connections

A high quality braided shield cable with 16 to 24 AWG stranded wire is recommended for load cell or summing box connections. Rout the load cell cable through the strain relief supplied on the bottom of the enclosure. Either four or six conductor cables can be used.



Do not tin the ends of the load cell wire! A terminal connection free from the effects of vibration and oxidation can be assured only if the load cell terminals securely grip a bare, stranded wire.

When using four conductor cables move the sense jumpers to the internal position. When using six conductor cables move the sense jumpers to the external position. Utilizing the (+) and (-) Sense leads of six conductor cables provides compensation for variations in the excitation voltage due to resistance changes in the cable. See Figure 9 for the load cell connector.

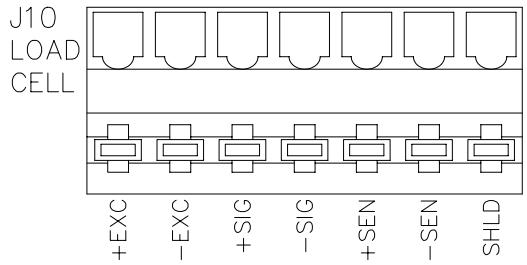
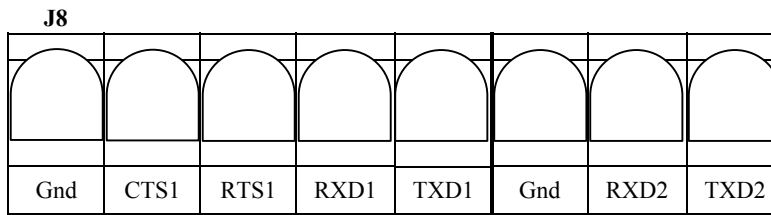

Figure 9: Model 350 IS and Model 355 IS Load Cell Connector (J10)

Communication Port Connections

The 350 IS and 355 IS come standard with two RS-232 communication ports. Every device connected to a communication port of the Model 350/355 IS must be approved for the appropriate hazardous area and entity parameters. Refer to the diagram below for connections to each communication port.



Remote Key Connections

The Model 350 IS and Model 355 IS accommodate two remote keys connections. A remote switch may be connected to J11 on the main board to provide remote activation of print, tare, or zero functions. The remote switch being connected must be approved for the appropriate hazardous area and entity parameters.

The connection for the remote switch input for remote key1 is between key 1 and GND. Connect a second remote switch to key 2 and GND.

A two-conductor shielded cable between 28 and 20 AWG is recommended. The input requires a contact closure from a push-button switch, a 'dry' relay contact, a photo-eye, and a proximity sensor or other such device. A closure initiates the operation specified at P800. A closed switch will conduct 2.2 mA.

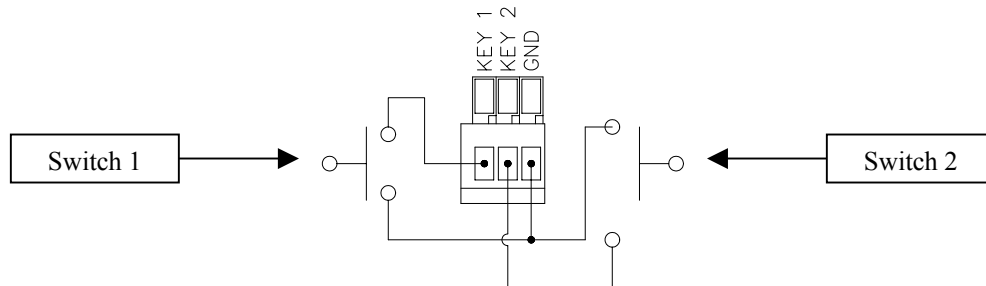

Figure 10: Remote Key Connection



Do not apply an external voltage to remote key terminals! Only a contact closure is required to activate the remote key input.

The open circuit voltage across the remote key pins is +5 VDC. A closed switch will conduct about 0.25 mA. Therefore, a low-voltage switch with gold-plated contacts is recommended. A Mercury-wetted switch will also work well. A minimum contact duration of 100 ms is required. Once invoked, the selected remote key operation will not repeat until the contact is released and closed again.

Hazardous Area Options

These options have been Factory Mutual approved to operate in a hazardous area.

BATTERY POWER SUPPLY (EXTERNAL)

Part number 24H350-3502A

The battery is enclosed in a stainless steel case and cannot be removed from the case. The battery module is mounted on the indicator swivel bracket. The battery will operate approximately 200 continuous use with LCD display (backlight off, 1 load cell and no options installed) or 100 hours with the LED display (one load cell and no options installed).

MOUNTING – SWIVEL BRACKET

1. Hold the battery module in both hands. Make sure the connectors on the battery module are facing the back of the indicator.
2. Line up the two protrusions on the battery module with the slide rails on the swivel bracket.
3. Push the module into the slide rails until the knobs drop into the slots in the swivel bracket.
4. Tighten the knobs to hold the battery module in the swivel bracket.

BATTERY CHARGING

The battery must be charged in the safe area. Connect the battery to the battery charger. Connect the battery charger to AC power. Charging will take approximately 3.5 hours.

LOW BATTERY INDICATION

The low battery annunciator will be lit when the voltage reaches a low threshold and the low battery message (Lo Bat) is shown on the display for 1.5 seconds every 15 seconds.

DEAD BATTERY SHUTDOWN

The indicator will shutdown after five minutes of dead battery condition.

AC TO DC POWER SUPPLY (EXTERNAL)

Part number 24H350-3501A

The AC- DC power supply is in a stainless steel enclosure which is remotely mounted. Capable of powering up to (2) 350/355 IS indicators in gas Groups C-G or IIB-IIA and (1) 350/355 IS indicator in gas Groups A-G or IIC-IIA. Refer to Figure 11 for mounting dimensions.

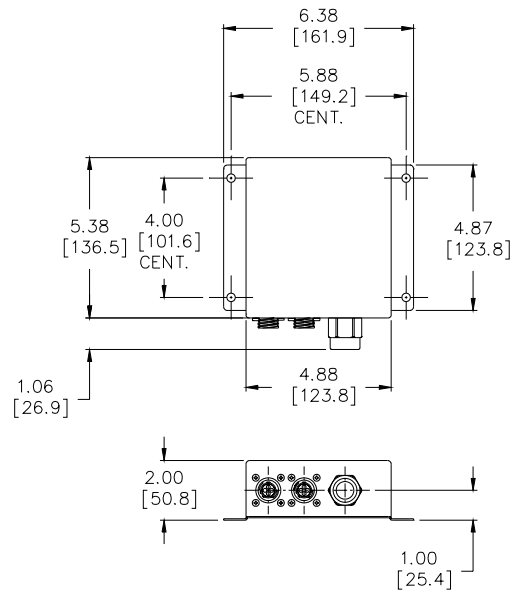

Figure 11: AC to DC Power Supply Outline Drawing

AC TO DC POWER SUPPLY EXTENSION CABLE

The extension cable comes in either 25' or 50' length. This is for mounting the AC to DC converter away from the indicator.

5 VOLT AND 8 VOLT EXCITATION

Two versions of excitation are available for the Model 350 IS and Model 355 IS. The 5-volt excitation consumes less power than the 8-volt excitation module. The 5-volt excitation is standard on the main board. The 8-volt excitation is on a separate board which is installed by the factory. The 5-volt excitation is +5V to 0V. The 8-volt excitation is +5V to -3V.

CHAPTER 3: CONFIGURATION

Entering the Setup Mode (Model 350 IS)

To prevent accidental changes to the Indicator Setup, a sequence of keystrokes is used to gain access to the Setup Mode:

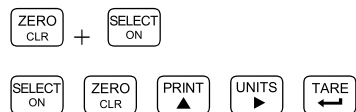

These keystrokes must be made within five seconds, or the indicator will return to the Weigh Mode.

To access the Setup Mode:

1. From the Weigh Mode, press +
DISPLAY READS ► Setup ~ Enter Code
2. Press
DISPLAY READS ► S
3. Press
DISPLAY READS ► SZ
4. Press
DISPLAY READS ► SZP
5. Press
DISPLAY READS ► SZPU
6. Press
DISPLAY READS ► Chgs ~ Poss!
P110.— — ~ F.S.= ~ 100

To access Setup in a view-only mode:

1. From the Weigh Mode, press +
DISPLAY READS ► Setup ~ Enter Code
2. Press
DISPLAY READS ► No ~ Chgs
P110.— — ~ F.S.= ~ 100



When exiting the Setup Mode, the Model 350/355 IS prompts whether to enter the Calibration Mode. (See *Chapter 4: Calibration* for Calibration Mode procedures). The display will then prompt to save any changes.

Entering the Setup Mode (Model 355 IS)

To prevent accidental changes to the Indicator Setup, a sequence of keystrokes is used to gain access to the Setup Mode:

1 0 0

2 3 6 4 0

These keystrokes must be made within five seconds, or the indicator will return to the Weigh Mode.

To access the Setup Mode:

1. From the Weigh Mode, key in 1 0 0
DISPLAY READS ► Setup ~ Enter Code
2. Key in 2 3 6 4 0
DISPLAY READS ► Chgs ~ Poss!
P110.— — ~ F.S.= ~ 100

To access Setup in a view-only mode:





1. From the Weigh Mode, key in 1 0 0
DISPLAY READS ► Setup ~ Enter Code
2. Press
DISPLAY READS ► No ~ Chgs
P110.— — ~ F.S.= ~ 100

Selecting a Parameter





To advance to the next parameter (Model 350 IS and Model 355 IS):

1. Press
DISPLAY READS ► P111.09 ~ 1Grad ~ 0.01
2. Press
DISPLAY READS ► P112.05 ~ Ztrac ~ 0.5 d
3. Continue pressing to advance through all setup parameters.

To access the previous parameter (Model 350 IS):

1. Press 
DISPLAY READS ►.
2. Press 
DISPLAY READS ► P111.09 ~ 1Grad ~ 0.01
3. Repeat   to back up one parameter.







To access the previous parameter (Model 355 IS):

1. Press 
DISPLAY READS ►.
2. Press 
DISPLAY READS ► P111.09 ~ 1Grad ~ 0.01
3. Repeat   to back up one parameter.



When accessing a parameter, the parameter number appears briefly. The display then toggles between the parameter name and selection. Pressing  will again briefly display the parameter number.

To access a specific parameter (for example P200) (Model 350 IS):



1. Press  four times to select the first digit.
DISPLAY READS ► 2
2. Press  to advance to the next digit.
DISPLAY READS ► 2.
3. Press  once to select the next digit.
DISPLAY READS ► 20
4. Press  to advance to the next digit.
DISPLAY READS ► 20.
5. Press  once to select the next digit.
DISPLAY READS ► 200
6. Press  to advance to the parameter.
DISPLAY READS ► P200.00 ~ Baud ~ 9600

To access a specific parameter (for example P200) (Model 355 IS):

1. Key in    
DISPLAY READS ► P200.00 ~ Baud ~ 9600

Changing a Parameter Value





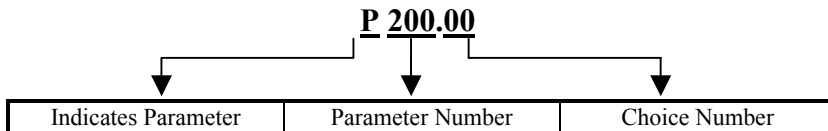

SELECTION PARAMETERS

Selection parameters have a pre-defined list of choices to pick from. Each choice is numbered and corresponds to a certain value. The choice number is shown to the right of the decimal point within the parameter number. Repeatedly pressing  (Model 350 IS) or  (Model 355 IS) while viewing a selection parameter cycles through the available choices, or you can key in the choice number.



For example, parameter 200 is a selection parameter that holds the baud rate for the serial. This is a selection parameter because a choice number between 00 and 06 must be used. Each choice number corresponds to a different baud rate. To change the baud rate from the default value of 9600 to 4800, perform the following steps from the Setup Mode.

To change the baud rate from the default value of 9600 to 4800:



1. Key in    
DISPLAY READS ► P200.00 ~ Baud ~ 9600
2. Press  (Model 350 IS) or  (Model 355 IS) once.
DISPLAY READS ► P200.01 ~ Baud ~ 4800

Key-In Parameters

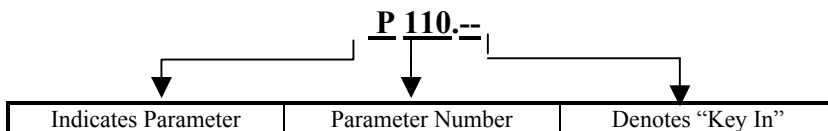
Key-In Parameters are not limited to a list of choices, although there may be upper and lower value limits. A Key-In Parameter requires that a numeric value be entered using the front panel keys. Key-In Parameters are shown with two hyphens after a decimal point within the parameter number.



To enter a Key-In Parameter (350 IS):







1. Press . A decimal point is used to represent the entry position.
2. Press  until the desired character appears.
3. Press . Another decimal point indicates the next entry position.
4. Repeat steps 1 and 2 until your desired entry value is shown.

5. Press  to enter your numerical value.





To enter a Key-In Parameter (355 IS):

1. Key in the number by using the numeric keys.
2. Press  to accept the entry.

To setup a full scale value of 250 lbs (350 IS):



1. Access the setup mode.
DISPLAY READS ► P110.— — ~ F.S.= ~ 100
2. Press  four times to select the first digit.
DISPLAY READS ► 2
3. Press  to advance to the next digit.
DISPLAY READS ► 2.
4. Press  six times to select the next digit.
DISPLAY READS ► 25
5. Press  to advance to the next digit.
DISPLAY READS ► 25.
6. Press  once to select the next digit.
DISPLAY READS ► 250
7. Press  to enter the value.
DISPLAY READS ► P110.— — ~ F.S.= ~ 250



To setup a full scale value of 250 lbs (355 IS):

1. Access the setup mode.
DISPLAY READS ► P110.— — ~ F.S.= ~ 100
2. Key in     to accept the entry.
DISPLAY READS ► P110.— — ~ F.S.= ~ 250





Saving Parameters

To exit the Setup Mode and save changes (350 IS):



1. Press  to begin exiting Setup Mode.
DISPLAY READS ► Enter ~ =CAL!
2. Press  to bypass Calibration Mode.
DISPLAY READS ► Enter ~ =Stor

3. Press  to save setup changes.
DISPLAY READS ► Enter ~ =End
4. Press  to complete exit.
DISPLAY READS ► 0.00





To exit the Setup Mode and save changes (355 IS):

1. Press  to begin exiting Setup Mode.
DISPLAY READS ► Enter ~ =CAL!
2. Press  to bypass Calibration Mode.
DISPLAY READS ► Enter ~ =Stor
3. Press  to save setup changes.
DISPLAY READS ► Enter ~ =End
4. Press  to complete exit.
DISPLAY READS ► 0.00





To exit the Setup Mode from the view-only mode (350 IS):

1. Press  to begin exiting Setup Mode.
DISPLAY READS ► Enter ~ =End
2. Press  to complete exit.
DISPLAY READS ► 0.00

To exit the Setup Mode without saving changes (350 IS):

1. Press  to begin exiting Setup Mode.
DISPLAY READS ► Enter ~ =CAL!
2. Press  to bypass Calibration Mode.
DISPLAY READS ► Enter ~ =Stor
3. Press  to exit *without* saving changes.
DISPLAY READS ► Enter ~ =Undo
4. Press  to undo changes.
DISPLAY READS ► Enter ~ =End
5. Press  to complete exit.
DISPLAY READS ► 0.00

















To exit the Setup Mode without saving changes (355 IS):

1. Press  to begin exiting Setup Mode.
DISPLAY READS ► Enter ~ =CAL!
2. Press  to bypass Calibration Mode.
DISPLAY READS ► Enter ~ =Stor
3. Press  to exit *without* saving changes.
DISPLAY READS ► Enter ~ =Undo
4. Press  to undo changes.
DISPLAY READS ► Enter ~ =End
5. Press  to complete exit.
DISPLAY READS ► 0.00











Factory Default

Parameter 65001 and 65002 are available to return the Model 350 IS to factory settings. Parameter 65001 will reset parameters including the calibration, while parameter 65002 resets all parameters accept the calibration.

Return to factory default (350 IS):

1. Access the setup mode. See page 18 for details.
2. Key in  or 
DISPLAY READS ► P65002~default-Cal
3. Press  once.
DISPLAY READS ► Are U sure?~default=Enter
4. Press  once.
DISPLAY READS ► Setup done~P65002~default-Cal
5. Press 

Return to factory default (355 IS):

1. Key in  or 
DISPLAY READS ► P65002~default-Cal
2. Press  once.
DISPLAY READS ► Are U sure?~default=Enter

3. Press  once.

DISPLAY READS ► *Setup done~P65002~default-Cal*

4. Press    

List of Parameters

The Model 350 IS and Model 355 IS have several parameters that can be configured to your specific application. Below is a table of the available parameters. Also refer to page 27 for explanations of each parameter.

Table 1: Parameter Map

Parameter Number	Display Name	Default Value	Valid Range/ Choices	Parameter Description	Page
P110.--	<i>F.S.=</i>	100.00	.01 – 999,999 (Keyed In)	Full Scale	27
P111.09	<i>1Grad</i>	.01	.00001 – 500 (24 Selections)	Count By	27
P112.05	<i>Ztrac</i>	0.5d	Off - 20.0d (200 Selections)	Zero Track Aperture	27
P114.10	<i>Stabl</i>	1.0d	Off – 20.0d (200 Selections)	Stability Window	27
P116.04	<i>Filtr</i>	1 Sec	.065 – 8.00 Sec (8 Selections)	Filter Setting	27
P117.01	<i>Rate=</i>	0.1 Sec	0.05 – 20.0 Sec (201 Selections)	Display Update	27
P118.12	<i>Zrang</i>	100%	.01 – 100% (13 Selections)	Zero Button Range	27
P150.00	<i>Units</i>	lb	lb / kg (Toggle)	Default (Calibration) Units	28
P151.01	<i>Unbut</i>	Enable	Enable / Disable (Toggle)	Units Button	28
P152.00	<i>Unit3</i>	None	None / ounce / gram / lb oz (4 Selections)	Additional Unit	28
P161.00	<i>TarSa</i>	Disable	Enable / Disable (Toggle)	Tare Save	28
P166.01	<i>AutoT</i>	Enable	Enable / Disable (Toggle)	Auto Tare	28
P169.00	<i>AtClr</i>	Disable	Enable / Disable (Toggle)	Auto Tare Clear	28
P171.00	<i>AnAlg</i>	Disable	Enable / Disable (Toggle)	Analog Output Option	28
P179.00	<i>Count</i>	Disable	Enable / Disable (Toggle)	Counting Functions	28
P200.00	<i>Baud1</i>	9600	150 – 115K (13 Selections)	Comm 1 Baud Rate	28
P201.01	<i>Data1</i>	8 Bits	7 – 8 Bits (2 Selections)	Comm 1 Data Bits	28
P202.00	<i>Par 1</i>	None	None – Odd (3 Selections)	Comm 1 Parity	29
P203.00	<i>Stop1</i>	1 Bit	1 – 2 Bits (2 Selections)	Comm 1 Stop Bits	29
P204.02	<i>HndS1</i>	Soft	None – Both (4 Selections)	Comm 1 Handshake	29
P210.01	<i>Send1</i>	Press	Off – Cycle (4 Selections)	Comm 1 Transmit	29



Parameter Number	Display Name	Default Value	Valid Range/ Choices	Parameter Description	Page
P212.01	<i>Stbl1</i>	Delay	Off – Delay (Toggle)	Comm 1 Motion	29
P213.01	<i>Ttyp1</i>	--1--	1 – 14, Custom (Selection)	Print Transmission	29
P220.00	<i>Baud2</i>	9600	150 – 115K (13 Selections)	Comm 2 Baud Rate	28
P221.01	<i>Data2</i>	8 Bits	7 – 8 Bits (2 Selections)	Comm 2 Data Bits	28
P222.00	<i>Par 2</i>	None	None – Odd (3 Selections)	Comm 2 Parity	29
P223.00	<i>Stop2</i>	1 Bit	1 – 2 Bits (2 Selections)	Comm 2 Stop Bits	29
P224.02	<i>HndS2</i>	Soft	None – Soft (2 Selections)	Comm 2 Handshake	29
P230.01	<i>Send2</i>	Press	Off – Cycle (4 Selections)	Comm 2 Transmit	29
P232.01	<i>Stbl2</i>	Delay	Off – Delay (Toggle)	Comm 2 Motion	29
P233.01	<i>Ttyp2</i>	--1--	1 – 14, Custom (Selection)	Print Transmission	29
P410.--	<i>Euro</i>	Disable	Enable / Disable 9991/9990 (Key In)	OIML Enforce	30
P420.01	<i>Dsply</i>	On	Off – Auto (3 Selections)	Display Function	30
P423.00	<i>Backlight</i>	Off	ON/OFF	Backlight	30
P440.00	<i>rStrc</i>	Disable	Enable / Disable (Toggle)	NTEP Enforce	30
P502.01	<i>disblt-dAt</i>	Disable	Enable / Disable (Toggle)	Time/Date Function	30
P503.01	<i>12 hours</i>	12 hour	12 hour/24 hour	Time/Date Function	30
P504.00	<i>Style</i>	U.S.A	U.S.A or International	Time/Date Function	31
P505.01	<i>TdSEL disbl</i>	Disable	Enable / Disable (Toggle)	Time/Date Function	31
P800.00	<i>R1bUtt</i>	None	None – Print/Tare (5 Selections)	Remote Button Function	31
P801.00	<i>R2bUtt</i>	None	None – Print/Tare (5 Selections)	Remote Button Function	31
P1000.--	<i>Cust. Trans</i>	--	--	Custom Transmit	31
P5000.00	<i>TArGt</i>	Disable	Enable / Disable (Toggle)	355 Target Key	31
P5002.00	<i>StoP</i>	Disable	Enable / Disable (Toggle)	355 Stop Key	31
P5003.00	<i>StArt</i>	Disable	Enable / Disable (Toggle)	355 Start Key	31
P5004.00	<i>Chec</i>	Auto	Auto / Start (Toggle)	355 Restart Mode	31
P5010.00	<i>SPAnn</i>	Enable	Enable / Disable (Toggle)	Setpoint Annunciators	32
P5011.00	<i>SPBar</i>	Disable	Enable / Disable (Toggle)	Bargraph Display	32
P5012.00	<i>BarPc</i>	50%	0 – 100 (Key In)	Bargraph Scaling	32
P5100.00	<i>SetPt</i>	None	None – Indep (8 Selections)	Setpoint Operation	32

PARAMETER MAP DETAILS

P110 Full Scale Value (Key in)

Denotes the full scale capacity. This value should not exceed the rated capacity of the weighing device.

P111 Division Size (Selection)

Indicates the count-by and decimal point. Pressing  +  (Model 350 IS) or  (Model 355 IS) will automatically select the choice closest to 10,000 divisions without exceeding 10,000 divisions.

P112 Zero Track Aperture (Selection)

Set in terms of number of divisions. Zero tracking eliminates small weight deviations at or near zero. Weight deviations within the selected window that have been stable for more than one second are tracked off, maintaining a gross or net zero condition.

The sum of weight values zeroed with auto zero tracking and  cannot exceed the allowable zero range (P118).

To determine the proper setting in a counting application, divide the weight of the smallest product counted by the division size (P111). Zero Track should be set to 0 (off) for most setpoint filling operations. This prevents tracking off any product trickle at the start of a fill process.

P114 Stability (Selection)

Stability is defined as weight fluctuations within an aperture that can be regarded as being a stable weight. Deviations outside this aperture are considered motion, and the motion annunciator on the front panel will light accordingly. Once the scale settles within the stability aperture, the indicator will wait one second before the indicator is considered stable.

Print operations configured as motion delayed (P114) will not send the specified data until the weight reflects a stable reading as designated by this setting. Certain setpoint operations are also considered motion delayed and will not change states until a no-motion condition exists.

P116 Filter (Selection)

Sets the indicator response time in terms of seconds. Filtering determines how quickly the indicator will respond to changing input signals. A low filter setting speeds the response, a higher filter setting will 'dampen' the response.

Filtering is used to filter out weight fluctuations caused by outside sources, such as vibrations or air currents.

P117 Rate (Selection)

Specifies how often the display is updated with new data. For example, if 0.05 is selected, the controller will write data to the display every time an analog/digital conversion is made. Since the A/D converter updates every 0.05 sec, selections from 0.05 to 20.0 seconds are available. This parameter also affects the transmission rate for continuous transmit. Actual transmission intervals are dependent upon system setup.

P118 Zero Range (Selection)

Specifies how many divisions can be zeroed in terms of a **percentage** of full scale (P110). The sum of weight values zeroed through the  key and auto zero tracking cannot exceed this range.

A zero range of 5% is commonly used with large tank scales to avoid accidental zeroing of a full or partially full tank.

P150 Units (Toggle)

Set default units to 'lb' or 'kg'. The indicator must use the default units during calibration procedures (see *Chapter 4*). The default units are the displayed units upon indicator power-up.

P151 Units Button (Toggle)

When enabled, this parameter will allow  to toggle the units between 'lb' and 'kg' (1000g). When disabled, the indicator will show only the calibration units as determined by P150.

P152 Third Unit (Selection)

This parameter will allow the choice of three additional units (ounces, grams or lb oz) that may be accessed with the  key. Only one unit will be available at a time. The third unit can only be selected if P151 is enabled. The third unit will be identified by an annunciator on the display. This unit selection is not legal for trade.

P161 Tare Save (Toggle)

Enabling Tare Save allows the indicator to retain the tare value in the event of power loss. The correct net weight is restored upon power-up.

P166 Auto Tare (Toggle)

When enabled, pressing  will wait for a no-motion condition and then bring the scale to a net zero reading. Disabling will prevent keypad tare operations.



Note that if a setpoint activation method is set to , disabling Auto Tare will also disable the activation of that setpoint.

P169 Auto Tare Clear (Toggle)

Enabling this feature will cause the current tare value to be cleared to zero every time the indicator stabilizes within ± 5 graduations of gross zero

P171 Analog (Toggle)

Future use.

P179 Count (Toggle)

When enabled, the quantity mode becomes accessible via the  key. The quantity mode is identified by the illumination of the QTY annunciator.

P200 Baud (Comm 1) (Selection)

Set the desired baud rate for the communication port. 150 – 115K bps

P201 Data Bits (Comm 1) (Toggle)

Select 7 or 8 data bits for the transmission.

P202 Parity (Comm 1) (Selection)

Select *Odd*, *Even* or *None* for the transmission parity.

P203 Stop Bits (Comm 1) (Toggle)

Select *1* or *2* stop bits for communication port transmissions.

P204 Comm Handshake (Comm 1) (Selection)

Select from *None*, *Software (Xon/Xoff)*, *Hardware (CTS/RTS)*, or *Both*.

P210 Send (Comm 1) (Selection)

Transmission Send options:

Choice Number	Selection Name	Description
P210.00	<i>Off</i>	All transmissions disabled.
P210.01	<i>Press</i>	Sends transmission with [PRINT] key.
P210.02	<i>Cont.</i>	Sends transmissions continuously.
P210.03	<i>Cycle</i>	Send single transmission after weight is reached and motion ceases. Must return display value below 0.1% of F.S. to reset for next transmission.

P212 Send Stability (Comm 1) (Toggle)

Enabling Send Stability will delay any transmissions until a no-motion condition exists.

P213 Transmit Selection (Comm 1) (Selection)

Select desired print output (1 – 14 or custom). The transmission will be initiated by the selected print operation (P210) and / or the Remote Key selection (P800). See page 32 for details on preset formats or page 34 for details on custom transmit.

P220 Baud (Comm 2) (Selection)

Set the desired baud rate for the communication port. 150 – 115K bps

P221 Data Bits (Comm 2) (Toggle)

Select 7 or 8 data bits for the transmission.

P222 Parity (Comm 2) (Selection)

Select *Odd*, *Even* or *None* for the transmission parity.

P223 Stop Bits (Comm 2) (Toggle)

Select *1* or *2* stop bits for communication port transmissions.

P224 Comm Handshake (Comm 2) (Selection)

Select from *Non* and *Software*.

P230 Send (Comm 2) (Selection)

Transmission Send options:

Choice Number	Selection Name	Description
P230.00	<i>Off</i>	All transmissions disabled.
P230.01	<i>Press</i>	Sends transmission with [PRINT] key.
P230.02	<i>Cont.</i>	Sends transmissions continuously.
P230.03	<i>Cycle</i>	Send single transmission after weight is reached and motion ceases. Must return display value below 0.1% of F.S. to reset for next transmission.

P232 Send Stability (Comm 2) (Toggle)

Enabling Send Stability will delay any transmissions until a no-motion condition exists.

P233 Transmit Selection (Comm 2) (Selection)

Select desired print output (1 – 14 or custom). The transmission will be initiated by the selected print operation (P210) and / or the Remote Key selection (P800). See page 32 for details on preset formats or page 34 for details on custom transmit.

P410 Euro (Toggle)

Enable OIML legal-for-trade restrictions (see *Chapter 5: Legal For Trade*).

P420 Display (Selection)

Select display control option. Choose from *On*, *Off* or *Auto*. The auto setting helps conserve power for extended battery life. When the indicator display is off, the load cell(s) are still powered.

If P420 is set to *Off* or selection 0, you can turn on the display by holding down the ZERO key upon power up. This does not set P420 to *On*; it only temporarily turns on the large VFD display in order to allow you to see what you are entering.

Parameter Setting	Choice	Description
P420.00	<i>Off</i>	Shuts off the display.
P420.01	<i>On</i>	Normal display operation.
P420.02	<i>Auto</i>	Shuts off the display when weight has stabilized within 6 divisions for 5 minutes. Pressing [ON] or changing weight more than 6 divisions will re-enable the display. NOTE: The display will turn back on if data is received via the RS-232 Port.

P423 Back Light (on/off)

Toggle the backlight on a 350/355 IS LCD

P440 Legal For Trade Restrictions (Toggle)



Enable NTEP legal-for-trade restrictions. See *Chapter 5: Legal For Trade*.

P502 Time/Date (toggle)

Enables or disables the time and date feature. If enabled the time and date will be accessible from the weigh mode with the SELECT key. See page 63 for instructions on how to change the time and/or date. Note: if disabled P503-P505 will not be accessible, however, their current settings will be retained for future use.

P503 Hours (toggle)

Determines the TIME format style, 12 hour or 24 hour. If in 12 hour mode the right most decimal point on the LED display will become the PM indicator. Note: The time must be entered as military time. If the mode is set for 12 hour, the time will be converted to a 12 hour clock.

- P504 Style (toggle)**
Determines the DATE format style, U.S.A. or Int'l. If set for U.S.A., the date will resemble 01/26/01. If set for international, the date will resemble 26/01/01.
- P505 Time/Date Select (toggle)**
Allows the time and date to be viewed with the  key from the weigh mode. The weight will continue to be updated when viewing the time or date. The time will be formatted as defined by P503 and the date will be formatted as defined by P504
- P800 Remote Key 1 Operation (Selection)**
Select function for Remote Key closure. Choose from *None, Print, Tare, Zero or Print/Tare*. If a setpoint is configured to use the remote key as an activation method, then the P800 setting is overridden. The *Remote Key Operation* section on page 66 details the remote key operation. See *Remote Key Connection* on page 15 for remote key electrical connections.
- P801 Remote Key 2 Operation (Selection)**
Select function for Remote Key closure. Choose from *None, Print, Tare, Zero or Print/Tare*. If a setpoint is configured to use the remote key as an activation method, then the P801 setting is overridden. The *Remote Key Operation* section on page 66 details the remote key operation. See *Remote Key Connection* on page 15 for remote key electrical connections.
- P1000 Custom Transmit**
A custom transmit is a user-defined string of data that can be sent to the serial port. Parameter P1000 is the beginning of the custom transmit table and must be enabled for transmit by selecting *cust* at P213. Parameters use three bytes of memory; ASCII characters and control codes use one byte. See P60001 for available memory. The custom transmit cannot be viewed or altered from the indicator. A custom transmit *must* be entered via the serial port. See *Custom Transmit Setup* on page 32 for details on designing and loading a custom transmit.
- P5000 355 Target Key (Toggle)**
Allows a target value to be entered or viewed. Sending a % <CTRL-A> using a serial device such as a computer is equivalent to pressing the Target key.
- P5002 355 Stop Key (Toggle)**
Enable or disable the use of the stop key from the 355 keypad. Pressing the stop key in the gross, net or quantity modes with setpoint(s) enabled will cause all setpoints to deactivate and pause. Sending a % <CTRL-F> using a serial device such as a computer is equivalent to pressing the Stop key.
- P5003 355 Start Key (Toggle)**
Enable or disable the use of the start key from the 355 keypad. Pressing the Start key in the weigh mode with setpoints enabled causes a paused setpoint operation to be resumed. In setpoint modes other than checkweighing, the Start key performs the same operation as a remote key. Sending a % <CTRL-E> using a serial device such as a computer is equivalent to pressing the Start key.
- P5004 355 Restart Checkweighing Mode (Toggle)**
Determines the method in which the checkweighing mode will be restarted. Auto will restart after return to zero or Manual will restart by pressing the  key. If Stop (P5002) is disabled, this function is disabled and parameter 5004 will not appear.

P5010 Setpoint Annunciators (Toggle)

Enables or disables the setpoint annunciators to the left of the main 7-segment display. Disabling the setpoint annunciators may be desired when the bargraph is enabled while using an LCD display. See *Bargraph* on page 40.

P5011 Setpoint Bargraph (Toggle)

Enables or disables the bargraph display on the LCD version of the Model 350/355 display. This setup parameter only appears if an LCD display is installed. See *Bargraph* on page 40.

P5012 Setpoint Bargraph Low-Limit Percentage (Key in)

Controls the "bargraph low-limit percentage" value for determining the *weighting* of each segment of the bar graph. This only appears if an LCD display is installed. See *Bargraph* on page 40.

P5100 Setpoint Operation (Selection)

Sets the desired Setpoint operation. Choose between *None*, *ChecP*, *Fill*, *Batch*, *Discharge*, *Both*, *ChecA* or *Independent*. See *General Setpoint Setup* on page 40 for complete details on setpoint setup and operation.

Preset Transmit Selections

The Model 350 IS and Model 355 IS provide 14 preset formats for printing tickets or sending data to a computer. Only one format or custom transmit may be enabled at a time.

Choice 0 Custom Transmit:

User-defined serial data string (see *Custom Transmit Setup* on page 32).

Choice 1 GSE Standard Transmit:

```
XXX.XX kg Gross<CR><LF>
XXX.XX kg Tare <CR><LF>
XXX.XX kg Net <CR><LF>
HH:MM:SS am MM/DD/YY <CR><LF>
```

Choice 2 Count:

```
HH:MM:SS am MM/DD/YY <CR><LF>
  XXX QTY <CR><LF>
  XX.X kg APW <CR><LF>
XXX.XX kg Gross<CR><LF>
XXX.XX kg Tare <CR><LF>
XXX.XX kg Net <CR><LF>
```

(NOTE: The time and date will only be printed in choice 1 and 2 if P502 is enabled).

Choice 3 (Condec Clone):

```
<STX> <POL> <DATA> <L/K> <G/N> <STAT> <CR> <LF>
```

Where:

<STX> is a single control code, decimal value of 2.

<DATA> is 8 characters, 1st character is either minus sign or a space, padded with leading spaces, with an embedded decimal point.

<L/K> is a single 'L' or 'K' character to indicate lb or kg units.

<G/N> is a single 'G' or 'N' character to indicate gross or net data.

<STAT> is an 'O' (overload/underload), 'M' (motion), or space otherwise.

<CR> is a single control code (carriage return), decimal value of 13.

<LF> is a single control code (line feed), decimal value of 10.

Choice 4:

<STX><Signed DATA><sp><lb/kg><sp><Gross/Net/Qty><STAT><CR>

Choice 5:

<STX><Signed DATA><sp><lb/kg><STAT><CR>

Choice 6:

<STX><Signed DATA><sp><lb/kg><CR>

Choice 7:

<STX><Unsigned DATA><sp><CR>

Choice 8:

<STX><Signed DATA><sp><lb/kg><sp><Gross/Net/Qty><STAT><SPS><CR>

Choice 9:

<STX><Signed DATA><sp><lb/kg><STAT><SPS><CR>

Choice 10:

<STX><Signed Displayed Weight><sp><lb/kg><SPS><CR>

Choice 11:

<STX><Unsigned Displayed Weight><SPS><CR>

Choice 12:

<STX><Unsigned DATA><sp><lb/kg><sp><Gross/Net/Qty><STAT><CR>

Use choice 12 to send to a 450/455/550 remote display that is set to text mode and a <CR> terminator.

Choice 13:

<STX><Unsigned DATA><sp><lb/kg><sp><Gross/Net/Qty><STAT> <CR><LF>

Choice 14 (Simulates NCI 3835):

<LF>Signed DATA<CR><LF><STAT><CR><ETX>

Data Block Name	Description
<STX>	A single control code, decimal value of 2.
<ETX>	A single control code, decimal value of 3.
<POL>	A <space> for positive data or a - for negative data.
<Signed DATA>	8 characters right justified, space padded, including a decimal point and polarity sign. Polarity is a '+' or '-' to the immediate left of the most significant digit.
<Unsigned DATA>	8 characters right justified, space padded, including a decimal point.
<lb/kg>	Two characters indicating pounds or kilograms.
<Gross/Net/PTY>	Single word for gross weight, net weight or quantity.
<STAT>	An 'O' (overload/underload), 'M' (motion), or <space> otherwise
<SPS>	See <SPS> Setpoint Status below.
<CR>	A single control code, decimal value of 13.
<LF>	A single control code, decimal value of 10.
<sp>	ASCII Space, decimal value of 32.

<SPS> Setpoint Status

Transmitting the setpoint status will reflect the current state of all the setpoints, regardless of which setpoint operation is configured. The status can be read as a single ASCII numeric character (0-7), a Hex value (30h-37h) or a binary bit comparison. Status is preceded by a <space> and an "S". The preceding data stream format is for fixed transmissions of <SPS> as specified above. This is not associated with the custom transmission of parameter P96.

SP 1	SP 2	SP3	ASCII	Hex	Bit Comparison
Off	Off	Off	0	30h	0011 0000
On	Off	Off	1	31h	0011 0001
Off	On	Off	2	32h	0011 0010
On	On	Off	3	33h	0011 0011
Off	Off	On	4	34h	0011 0100
On	Off	On	5	35h	0011 0101
Off	On	On	6	36h	0011 0110
On	On	On	7	37h	0011 0111

Custom Transmit

The serial output of the Model 350/355 IS can be configured for a custom application such as a remote display format, a customized computer program format, or a customized ticket format. The custom transmit must be designed in a computer-transmittable ASCII text file. The custom transmit can only be loaded into the indicator through the serial port. P213 must be set to 0 to select the custom transmit format for transmission.

ELEMENTS OF A CUSTOM TRANSMIT

Parameters, ASCII text, and control codes are the elements of a custom transmit.

Parameters

Certain parameters related to weight, quantity, setpoints and status can be sent out of the comm port. Gross Weight, Target 1 and Quantity are examples of printable parameters.

ASCII Text

ASCII text can be entered into a custom transmit to provide further detail of a transaction. “P”, “@” and “+” are examples of ASCII text.

Control Codes

You can custom transmit ASCII control codes to control a printing device. <CR> (carriage return) and <FF> (form feed) are examples of control codes.

WRITING A CUSTOM TRANSMIT ASCII TEXT FILE

Any text editor may be used to construct a custom transmit (Notepad, Wordpad, etc.), but you must save the custom transmit as a text (.txt) file. Instructions can also be sent keystroke by keystroke from a communications program. To do so, ignore the Model 350/355 IS display and enter the characters in the correct order. Figure 12 shows a custom transmit written in Wordpad.

ACCESSING SETUP AND CLEARING EXISTING CUSTOM TRANSMIT

Every custom transmit file must start with:

```
1999%s%s%z%p%u%e
%c%e
```

This accesses the Setup Mode at the end of the existing transmit and then clears the transmit so that a new one may be entered.

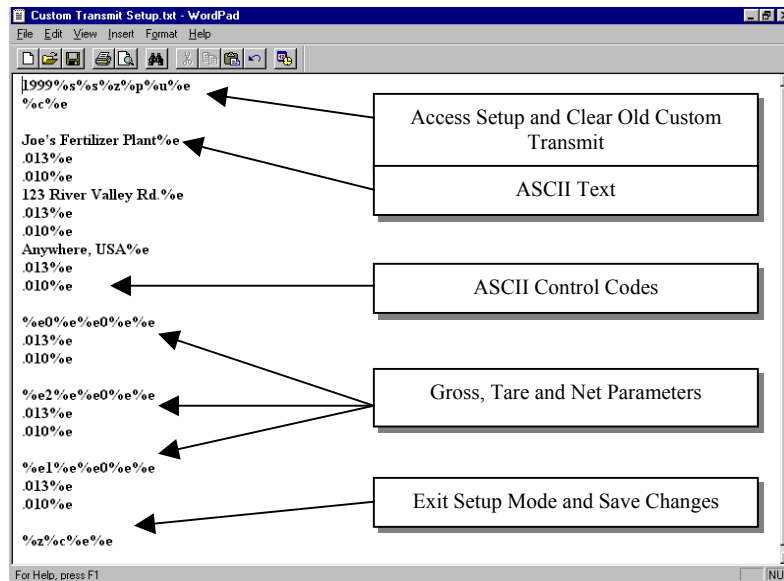

Figure 12: Custom Transmit File

ENTERING ASCII TEXT

ASCII text is defined as printable characters, including alpha- numerics as well as punctuation and symbols. See Table 4 for a complete listing of ASCII characters. ASCII text can be entered directly into a custom transmit with a %e (enter command). For example, **Joe's Fertilizer Plant%e**.

ENTERING ASCII CONTROL CODES

Some ASCII characters are known as control codes, non-printable characters that instruct a printing device to perform certain functions. For example, a carriage return <CR> forces a printer to move the print head to the left-most position of the current line. A line feed <LF> forces the print head to move down one line. Enter control codes with a decimal point, a 3-digit ASCII code, and a %e. For example, **.013%e**.

Table 2: ASCII / HEXADECIMAL CONVERSION CHART

										HEX	CHAR	DEC		
00	NUL	000	1A	SUB	026	34	4	052	N	078	68	h	104	
01	SOH	001	1B	ESC	027	35	5	053	4F	O	079	69	i	105
02	STX	002	1C	FS	028	36	6	054	50	P	080	6A	j	106
03	ETX	003	1D	GS	029	37	7	055	51	Q	081	6B	k	107
04	EOT	004	1E	RS	030	38	8	056	52	R	082	6C	l	108
05	ENQ	005	1F	US	031	39	9	057	53	S	083	6D	m	109
06	ACK	006	20	SP	032	3A	:	058	54	T	084	6E	n	110
07	BEL	007	21	!	033	3B	;	059	55	U	085	6F	o	111
08	BS	008	22	“	034	3C	<	060	56	V	086	70	p	112
09	HT	009	23	#	035	3D	=	061	57	W	087	71	q	113
0A	LF	010	24	\$	036	3E	>	062	58	X	088	72	r	114
0B	VT	011	25	%	037	3F	?	063	59	Y	089	73	s	115
0C	FF	012	26	&	038	40	@	064	5A	Z	090	74	t	116
0D	CR	013	27	‘	039	41	A	065	5B		091	75	u	117
0E	SO	014	28	(040	42	B	066	5C	\	092	76	v	118
0F	SI	015	29)	041	43	C	067	5D]	093	77	w	119
10	DLE	016	2A	*	042	44	D	068	5E	^	094	78	x	120
11	DC1	017	2B	+	043	45	E	069	5F	_	095	79	y	121
12	DC2	018	2C	‘	044	46	F	070	60	`	096	7A	z	122
13	DC3	019	2D	-	045	47	G	071	61	a	097	7B	{	123
14	DC4	020	2E	.	046	48	H	072	62	b	098	7C		124
15	NAK	021	2F	/	047	49	I	073	63	c	099	7D	}	125
16	SYN	022	30	0	048	4A	J	074	64	d	100	7E	~	126
17	ETB	023	31	1	049	4B	K	075	65	e	101	7F	DEL	127
18	CAN	024	32	2	050	4C	L	076	66	f	102			
19	EM	025	33	3	051	4D	M	077	67	g	103			



Most printers require a carriage return (.013) and/or a line feed (.010) to print preceding data and avoid leaving data in the printer buffer. See page 35 for a list of ASCII codes.

PARAMETER SELECTION NUMBERS

The following sequence enters parameters into a custom transmit: %e , the parameter number, %e%e , a format code, and then %e%e with no intervening spaces.

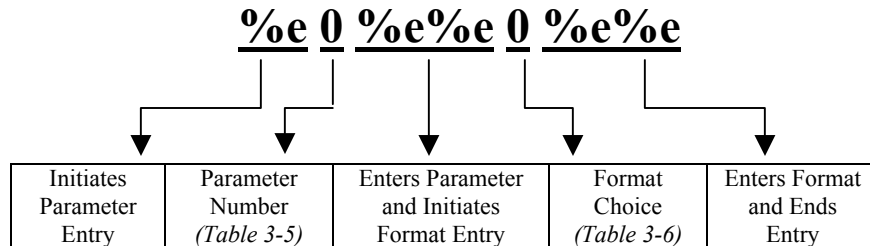

Table 3: Custom Transmit Parameter Selection Numbers

Parameter Name	Parameter Number	Sample Print Output
Gross Weight	0	27.49 lb Gross
Net Weight	1	14.53 lb Net
Tare Weight	2	12.96 lb Tare
Time / Date	11	10:01:01 am 01/26/01
Quantity	30	58 Qty
APW	34	0.25 lb APW
APW * K	35	250 lb APW * K
Targ1	60	400 lb Targ1
Targ2	64	500 lb Targ2
Targ3	66	1000 lb Targ3
Act 1 (note: Indp. SP1)	70	600 lb Act 1
Rst 1 (note: Indp. SP1)	71	10 lb Rst 1
Act 2 (note: Indp. SP2)	72	300 lb Act 2
Rst 2 (note: Indp. SP2)	73	10 lb Rst 2
Act 3 (note: Indp. SP3)	74	100 lb Act 3
Rst 3 (note: Indp. SP3)	75	5 lb Rst 3
Setpoint Status	96	Setpt 0
Stability Status	97	Stat M
Displayed Value	98	16.34 lb Gross

The default format code for all parameters is 0. This prints all numeric data with 8 characters, right justified, left spaces filled., the units (if applicable) and the parameter name. The format choices for all parameters (except Stability Status and Setpoint Status) are shown in Table 4.

Table 4: Custom Transmit Format Codes

Choice	Sample Print Result	Description
Weight Parameter Format Codes		
0	“ 27.49 lb Gross”	Fixed width (8 characters), right justified, left spaces filled.
1	“000027.49 lb Gross”	Fixed width (8 characters), right justified, left zeroes filled.
2	“27.49 lb Gross”	Fixed width, left justified, right spaces filled.
3	“27.49 lb Gross”	Minimum possible width.
8	“400. lb Net”	Print decimal point, even if data has no fractional portion.
16	“+400 lb Net”	Print “+” for positive numbers.
32	“336.52 Net”	Do NOT print parameter units (lb or kg).
64	“336.52 lb Net”	Print value in “default” units (as opposed to current viewed units).
128	“336.52 lb”	Do NOT print parameter name.

Time/Date Format Codes		
1	"10:07:40 am 01/26/01"	Includes seconds with time.
2	"10:08 01/26/01"	24 hour time format.
4	"10:11 am Jan 26, 2001"	Print date spelled out.
8	"10:12 am Fri 01/26/01"	Print day of the week.
16	"10:12 am 26/01/01"	International date format.
32	"980503984 Tm/Dt"	# of seconds since 12:00 AM Jan 1, 1970.
64	"01/26/01"	Do NOT print time.
128	"10:14 am"	Do NOT print date.

If a combination of format choices is required, add the choice numbers together and enter their sum as the format code. For example, to print the net weight without the name (Net) or units (lb) and to print it minimum width:

NOTE: Only one of the choices 0-3 may be used at one time.

Choice	Sample Print Result	Description
3	"336.52 lb Net"	Minimum possible width.
32	"336.52 Net"	Do NOT print parameter units.
128	"336.52 lb"	Do NOT print parameter name.
Use the sum of the desired choice selections: 3 + 32 + 128 = 163		
163	"336.52"	Minimum possible width. Do NOT print parameter units. Do NOT print parameter name.

EXITING SETUP MODE AND SAVING CHANGES

Each custom transmit file must end with:

`%z%c%e%e`



This exits the Setup Mode, bypasses the calibration procedure and saves the indicator configuration file.

Parts Counting



The counting parameter must be enabled before the quantity mode is available. Refer to page 28 for details on the counting parameter and page 18 to enter the setup mode, make changes and save the change.

To sample using selectable fixed counts (350 IS):





- From the Weigh Mode, Press to view the current net weight.
DISPLAY READS ► 1.05
- Press until the QTY annunciator is lit. The display may show **do APS** if there is no APW.
DISPLAY READS ► 0
- Press to perform an auto-tare. The scale prompts to add 10 pieces.
DISPLAY READS ► Add ~ 10

- Press  to toggle sample amounts between 5, 10, 20, 50 and 100.
DISPLAY READS ► Add ~ 20
- Add the pieces to be sampled and press  to sample and display the current quantity.
DISPLAY READS ► 20



To sample using selectable fixed counts (355 IS):

- Press  to perform an auto-tare. The scale prompts to add 10 pieces.
DISPLAY READS ► Add ~ 10
- Press  to toggle sample amounts between 5, 10, 20, 50 and 100.
DISPLAY READS ► Add ~ 20
- Add the pieces to be sampled and press  to sample and display the current quantity.
DISPLAY READS ► 20

To sample using variable counts (350 IS):

- From the Weigh Mode, Press  to view the current net weight.
DISPLAY READS ► 1.05
- Press  to view the current quantity/count.
DISPLAY READS ► 0
- Press  to perform an auto-tare. The scale prompts to add 10 pieces.
DISPLAY READS ► Add ~ 10
- Add pieces, key in **36**, then press  to sample as 36 pieces and display the current quantity.
DISPLAY READS ► 36

To sample using variable counts (355 IS):

- Press  to perform an auto-tare. The scale prompts to add 10 pieces.
DISPLAY READS ► Add ~ 10
- Add pieces, key in **36**, then press  to sample as 36 pieces and display the current quantity.
DISPLAY READS ► 36

Setpoint Setup

The Model 350/355 IS has several pre-programmed scale setpoint applications available at P5100. Various related setpoint parameters may appear according to which of the standard programs is chosen. Table 5 describes the available setpoint operations.

Table 5: Setpoint Operations

Setpoint Selection	Function	Description	Page Ref
P5100.00	<i>None</i>	Setpoints disabled.	
P5100.01	<i>ChecP</i>	Percentage check-weighing. Over/Under tolerances are based on a percentage of the target weight.	46
P5100.02	<i>Fill</i>	Single Ingredient Fill (Single or Dual-Speed). Allows the use of pre-acts for dribble feed and compensation for free-fall material. Includes a selectable 'learn' mode.	48
P5100.03	<i>Batch</i>	Batch up to three ingredients. Allows for the use of pre-acts to compensate for free-fall material. Includes selectable 'learn' modes.	49
P5100.04	<i>Dschg</i>	Single Ingredient Discharge (Single or Dual-Speed). Allows the use of pre-acts for dribble feed and compensation for free-fall material. Includes a selectable 'learn' mode.	51
P5100.05	<i>Both</i>	Single Ingredient Fill and Discharge. Fill large holding vessels and discharge material in pre-determined amounts. Allows for the use of pre-acts to compensate for free-fall material. Includes a selectable 'learn' mode.	53
P5100.06	<i>ChecA</i>	Absolute check-weighing. Over/Under tolerances are based on discrete values.	55
P5100.07	<i>Indep</i>	Independent Setpoints. Activation based on specific target values. Includes selectable reset conditions.	57
P5100.08	<i>Checb</i>	Target Deviation check-weighing. Over/Under tolerances are deviated from the target weight.	59

Each program utilizes the three annunciators located to the left of the main display to give a visual status of the setpoint. A setpoint option board may be installed to allow control of an external device (see *Setpoint Card Connections* on page).

ACTIVATION METHODS (GENERAL)

Setpoint activation for Fill, Batch, Discharge, and Both can be initiated in one of four ways: Tare, Remote, Auto and Start key (355 IS only). Check-weigh operations have no start function but there are two methods of restarting. See parameter 5004 on page 31 for more details. Independent setpoint operations are limited to Above or Below activation. The Model 350 IS and Model 355 IS setpoint option board may be connected in-series with a larger automated control system or a manually activated switching device. A foot switch, a two-hand safety station, or other permissive-start devices may be used for safety or system compatibility.

Activation Method (P5003)	Description
Start Key (355 IS only)	The  activates the setpoint. It waits for a no-motion condition. The appropriate setpoint is then activated.

Activation Method (P5003)	Description
Tare Operation	 activates the setpoint. It waits for a no-motion condition, then tares scale to net zero. The appropriate setpoint is then activated.
Remote Keys	The [REMOTE KEY] closure activates the setpoint. The remote key function (assigned at P800) is <i>over-ridden</i> .
Auto-Start	Automatically activates the setpoint after motion ceases.

PRE-ACTS (GENERAL)

Pre-Acts are control actions prior to reaching a desired target value. Necessary to prevent over-filling due to product flow rate, relay and valve response time and product suspension, Pre-Acts compensate for other system variables affect how much *more* product reaches the weighing device after the indicator has deactivated a setpoint.

Pre-act 1

Used in dual-speed applications, pre-act 1 specifies when the 350/355 IS should switch from fast-fill to slow-fill, allowing the system to perform the bulk of a filling operation as quickly as possible before switching to a more manageable dribble mode for final cutoff. When using a single-speed device, set pre-act 1 to 0.

Pre-act 2

Specifies the weight where the final cutoff should occur, enabling the 350/355 IS to compensate for a dispensing control's closure time and account for free-fall material. Free-fall is the amount of product that has passed the point of the dispensing control yet not yet reached the weighing device.

Pre-act values are entered in terms of the amount of product that would over-fill or 'how early' to close the control device. For instance, after repeated tests, a system consistently over-fills by .5 lbs. This is the value that should be entered as the pre-act. The 350/355 IS would then deactivate the setpoint .5 lbs. less than the desired final target value.

Parameter Setting	Actual Cutoff Value	Comments
Target = 400 lbs.		Desired final weight.
Pre-Act 1 = 28	$400 - 28 = 372$	Switch to slow feed at 372 lbs.
Pre-Act 2 = .5	$400 - 0.5 = 399.5$	Final fill valve closes at 399.5 lbs.

LEARN FEATURE (GENERAL)

The 350/355 IS can 'learn' optimal pre-act values. When enabled, the learn feature will automatically adjust the final cutoff value based on an analysis of the five previous fills, helping achieve a final target by compensating for product viscosity, changes in plant air pressures, sticky valves, etc. For each cycle, the prior five final weights are analyzed and a new pre-act value is calculated.

PAUSE FEATURE (GENERAL)





The 350/355 IS can pause setpoint operations. This is useful to provide a pause for mid-cycle operator breaks, mechanical adjustments, etc.

Pause Setpoints on the Model 350 IS

When invoked, Pause deactivates all setpoints. The display will show: *Tare= ~ Abort*. Pressing  will abort the current cycle; any other keypress will resume the cycle. The Pause feature has four settings:



Pause Setting	Action	Result
Disabled		Pause feature disabled.
Keypad	350/355 IS Key Press	Current cycle paused – all setpoints deactivated.
Remote Key	Remote Key Contact Closure	Current cycle paused – all setpoints deactivated.
Both	350/355 IS Key Press OR Remote Key Contact Closure	Current cycle paused – all setpoints deactivated.



Pause Setpoints on the Model 355 IS





When invoked, Pause deactivates all setpoints. Pressing the  key will pause the setpoints. The display will show: *Abort ?Pause ~ Stop = Abort*. Pressing the  key again will abort the setpoints. Pressing the  key will resume all setpoints. In the independent setpoint mode, the setpoints will remain deactive until the  key is pressed.

CHANGING TARGETS FROM THE WEIGH MODE (GENERAL)

When a setpoint operation is configured from the Setup Mode, certain parameters are made available in the Weigh Mode. Pressing  cycles through available modes (Gross, Net, Quantity, Targ 1, etc.).

When viewing a setpoint-related parameter from the Weigh Mode,  takes on a special function. Data keyed in prior to  will be displayed as the new setpoint parameter value. Pressing  alone will advance to the first *subset* for the current setpoint parameter. Pre-acts and tolerances are subsets of their respective target values.

The Model 355 IS has a Target key to simplify the process of entering a target. Press the  and key in the target value and press .

A negative target value may be entered for the independent setpoints only. To enter the negative sign press  then  +  (Model 350 IS) or press  to display a negative sign (Model 355 IS). Continue with the entry by pressing the corresponding numeric keys.

Programs that involve a discharge cycle are loss-in-weight type applications. Any target or pre-act values for these programs should be entered as *positive* numbers. The 350/355 IS will automatically interpret these values as negative.

CHANGE TARGET WEIGHT EXAMPLE (GENERAL)

The target for the fill setpoint operation is Targ 1. This is a setpoint-related parameter and automatically becomes an available mode when Fill is configured in the setpoint setup. Pre-act 1 and pre-act 2 are *subsets* of Targ 1. The following procedure illustrates how to change a target from 250 lbs to 400 lbs., keep pre-act 1 at 28 lbs. and change pre-act 2 from 1.5 lbs to .5 lbs.

To change targets from the Weigh Mode (350 IS):

1. Press .
DISPLAY READS ►0.00
2. Press to view the current fill target.
DISPLAY READS ►Targ1 ~ 250
3. Press **400** to set a new fill target of 400 lbs.
DISPLAY READS ►Targ1 ~ 400
4. Press to select the Pre-Act 1 (subset) value of 28 lbs.
DISPLAY READS ►PA 1 ~ 28
5. Press to select the Pre-Act 2 (subset) value of 1.5 lbs.
DISPLAY READS ►PA 2 ~ 1.5
6. Press **.5** to select a new Pre-Act 2 value of .5 lbs.
DISPLAY READS ►PA 2 ~ .5
7. Press to display the current Gross Weight.
DISPLAY READS ►15.12

To change targets from the Weigh Mode (355 IS):

1. Press to view the current fill target.
DISPLAY READS ►Targ1 ~ 250
2. Key in the new target value and press . Example
DISPLAY READS ►Targ1 ~ 100

BARGRAPH (GENERAL)

A bargraph display is available for the ChecP, Fill, Batch, Dschg, Both and ChecA setpoint modes of operation. To enable the bargraph, refer to parameter P5011 (SPbar) in the *Parameter Map* section beginning on page 25. To weight each segment of the bargraph refer to parameter P5012 (bArPc) in the *Parameter Map* section beginning on page 25.

SCALING FOR “BARS” (BARGRAPH ARROWS)

If the first bar turns off at the specified percentage (set at P5012) of the low limit, and the last bar turns off at the low limit, then the difference will be divided by 8 to determine the number of lbs per bar. At less than 5 grads, the entire graph is off.

Example#1: “ChecP” (refer to)

- Lower Limit is set at 50lbs.
- **P5012** is set for **80%**
- (**Bar weight** = 50 – 40 = 10)
(10/8 = **1.25 lbs**)

NOTE: Right-side bars will have the same scaling (lb per bar) as the left-side bars. They are represented as a mirror image of each other.

<u>Bars ON</u>	<u>Weight Range (Lower Tolerance Limit)</u>
9	< 40
8	40.00 to 41.25
7	41.25 to 42.50
6	42.50 to 43.75
5	43.75 to 45.00
4	45.00 to 46.25
3	46.25 to 47.50
2	47.50 to 48.75
1	48.75 to 50.00

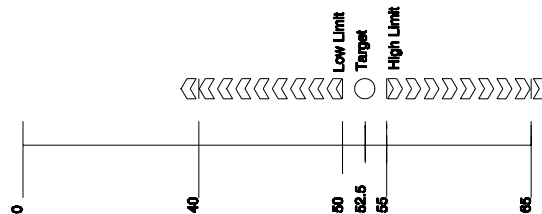

Figure 13: Example #1 Bargraph Segments (Weight Value)

Example#2: : “ChecP” (refer to

Figure 13)

- Lower Limit is set at 50lbs.
- **P5012** is set for **20%**
- (**Bar weight** = 50 – 10 = 40)
(40/8 = **5 lbs**)

NOTE: Right-side bars will have the same scaling (lb per bar) as the left-side bars. They are represented as a mirror image of each other.

<u>Bars ON</u>	<u>Weight Range (Lower Tolerance Limit)</u>
9	< 10
8	10.00 to 15.00
7	15.00 to 20.00
6	20.00 to 25.00
5	25.00 to 30.00
4	30.00 to 35.00
3	35.00 to 40.00

- 2 40.00 to 45.00
- 1 45.00 to 50.00

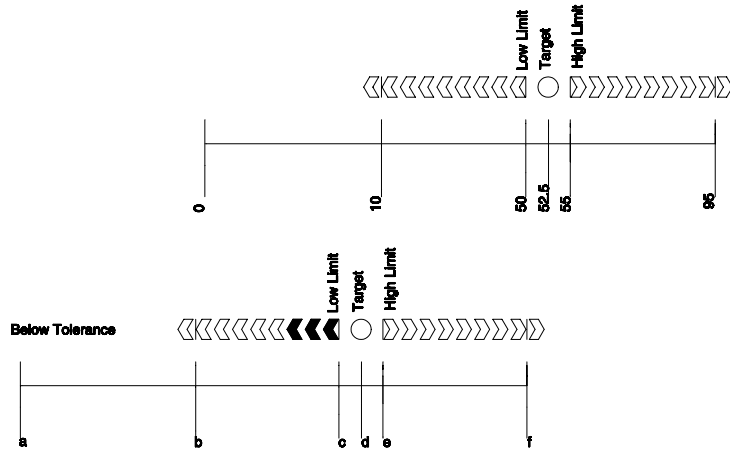

Figure 14: Example #2 Bargraph Segments (Weight Value)

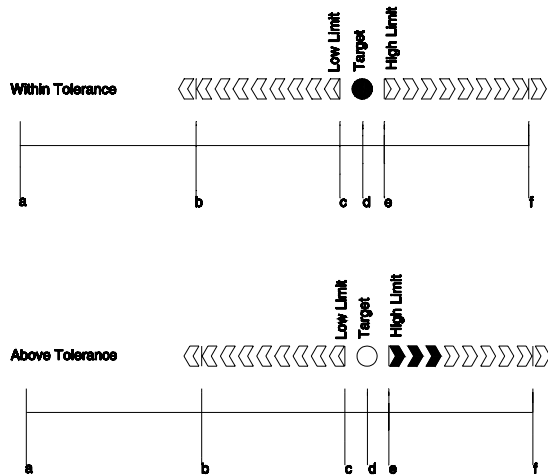

Figure 15: Examples of the Bargraph "Below, Within and Above Tolerance"

NOTE: (bargraph for filling and emptying modes)

For modes other than check-weighing, the bars will be on *only* while the setpoints are on and during the "Done" at the end of a fill.

The bar weights will be calculated similar to the check-weigh modes of operation stated above for filling, batching, etc., except that the percentage will be based on the actual target, rather than the low-limit value (see the equation below). The operation for emptying (and the emptying portion of 'both') will be the same except that the weight will be going negative while the left side bars are turning off.

$$\text{Bargraph segment weight} = \frac{\text{Target} - \left(\frac{[(\% \text{ set at P5012}) \cdot \text{Target}]}{100} \right)}{8.5}$$



Although the setpoint annunciators are not motion-inhibited, the setpoint relay outputs will not activate until a no-motion condition exists.

Percentage Check-Weighing

This feature is commonly used in check-weigh applications. After a target weight is entered, upper and lower tolerances are entered as a percentage of the target. Over and under tolerance values are automatically calculated according to the percentages entered. The desired target may be based on gross weight, net weight or quantity (if counting is enabled). Only the annunciators will light to indicator the setpoint status. Physical setpoints cannot be added at this time. The setpoint modules will be available in the near future and will be installed in a safe area hub.

Table 6: Setpoint Setup (Percentage Check-Weighing)

Setpoint Selection	Function	Description
P5100.1	ChecP	Check-weigh by percentage.
P5101.--	Targ1	Absolute target value.
P5102.--	PctLo	Low acceptance percentage.
P5103.--	PctHi	High acceptance percentage.
P5104.0	Based	Select from <i>Net</i> , <i>Gross</i> or <i>Quantity</i> .

See *Key-In Parameters* on page 21 for instructions on using the front panel keys for entering data.

SETPOINT ACTIVATION (PERCENTAGE CHECK-WEIGHING)

In order for the annunciators to activate, the displayed value must be at least five graduations above zero.

Check-Weigh Status	Annunciator Status	Annunciator Color (LED)
OVER	SP 1 Illuminated	Red
GOOD	SP 2 Illuminated	Green
UNDER	SP 3 Illuminated	Yellow









The Pre-Acts, Learn Mode, and Pause Feature options are not applicable to check-weigh operation.







CHANGING TARGETS FROM THE WEIGH MODE (PERCENTAGE CHECK-WEIGHING)

When Check-Weigh by Percentage is configured in the setpoint setup, the Targ 1 value automatically becomes an available mode for the **SELECT** key. It is possible to accept the applied weight as the target. Instead of keying in the target value from Targ 1, press **TARE** (350 IS) or **SAMPLE ENTER** (355 IS). Press **TARE** (350 IS) or **SAMPLE ENTER** (355 IS) again to accept the target. PctLo and PctHi are the subsets for Targ 1. PctLo and PctHi are entered as percentage values.

To change targets from the Weigh Mode (350 IS):

1. Press .
DISPLAY READS ►0.00
2. Press  to view the current fill target.
DISPLAY READS ►Targ1 ~ 250
3. Press **400**  to set a new fill target of 400 lbs.
DISPLAY READS ►Targ1 ~ 400
4. Press  to select the Pre-Act 1 (subset) value of 28 lbs.
DISPLAY READS ►PA 1 ~ 28
5. Press  to select the Pre-Act 2 (subset) value of 1.5 lbs.
DISPLAY READS ►PA 2 ~ 1.5
6. Press **.5**  to select a new Pre-Act 2 value of .5 lbs.
DISPLAY READS ►PA 2 ~ .5
7. Press  to display the current Gross Weight.
DISPLAY READS ►15.12

To change targets from the Weigh Mode (355 IS):

1. Press  to view the current fill target.
DISPLAY READS ►Targ1 ~ 250
2. Key in the new target value and press . Example  .
DISPLAY READS ►Targ1 ~ 100

EXAMPLE (PERCENTAGE CHECK-WEIGHING)

With a system set up to check-weigh ice cream containers, the following settings might be used to guarantee container weights from 1.98 to 2.04 lbs.:

Parameter Setting	Acceptable Check-weigh Values	Comments
Target = 2.00		Desired container weight.
Percent Lo Value = 1	$2.00 * .01 = 0.02$	Low acceptable range = 1.98 to 2.00.
Percent Hi Value = 2	$2.00 * .02 = 0.04$	High acceptable range = 2.00 to 2.04.

Fill

The fill program is used for single-speed or dual-speed filling operations. The dual-speed fill operation allows for both a fast and a slow fill mode. During a fast-fill, setpoints 1 and 2 are activated. During a slow-fill or single-speed fill, only setpoint 1 is activated.

Table 7: Setpoint Setup (Fill)

Setpoint Selection	Function	Description
P5100.1	Fill	Select Fill Setpoint Operation
P5101.--	Targ1	Final Fill Target Value
P5104.0	Based	Select between Net or Quantity
P5105.--	PA 1	Pre-Act 1 Value (Fast-to-Slow Value; 0 for Single-Speed)
P5107.0	Start 1	Setpoint Activation Method
P5109.--	PA 2	Pre-Act 2 Value (Final Cutoff)
P5110.1	Learn 2	Learn Feature for Pre-Act 2
P5114.1	PrAc 1	Pre-Act 1 Available as Subset in Weigh Mode
P5115.1	PrAc 2	Pre-Act 2 Available as Subset in Weigh Mode
P5116.1	Pause	Keypad Press invokes Pause

See *Key-In Parameters* on page 21 for instructions on using front panel keys for entering data.

ACTIVATION METHOD (FILL)

The fill begins with the selected activation method. The deactivation of the setpoints is automatic. The desired target may be based on net or quantity (if counting is enabled). See *Activation Methods (General)* on page 40 for activation details.

Fill Status	Annunciator Status	Setpoint Status (Requires Setpoint Option Board)
Fast Fill	SP 1 & SP 2 Illuminated	Relay 1 and Relay 2 Contacts Closed
Dribble Fill (or Single-Speed Fill)	SP 1 Illuminated	Relay 1 Contacts Closed
Fill Done or Pause	SP 1 & SP 2 Off	Relay 1 and Relay 2 Contacts Open

PRE-ACTS (FILL)

Pre-act 1 is used for dual-speed filling. Pre-act 1 specifies when the M350 should switch from fast-fill to slow-fill. When using a single-speed device, pre-act 1 should be set to 0 from the Setup Mode. Disabling P5114 and/or P5115 only removes them from the menu but still uses any value entered in the parameters as preact values.

Pre-act 2 specifies the target where the final cutoff should occur, regardless of a single-speed or dual-speed operation. See *Pre-acts (General)* on page 41 for details on the operational functions of pre-acts.



Pre-act 1 controls setpoint 2. Pre-act 2 controls setpoint 1.





LEARN FEATURE (FILL)

Pre-act 2 has a learn feature available which allows the indicator to adjust the final cutoff based on changing environmental conditions. See *Learn Feature (General)* on page 41 for ‘learn’ feature details.

PAUSE FEATURE (FILL)

The standard pause feature (keypress, remote key closure or both) is available for the fill operation. See *Pause Feature (General)* on page 41 for ‘pause’ function details.

CHANGING TARGETS FROM THE WEIGH MODE (FILL)

When Fill is configured in the setpoint setup, Targ 1 automatically becomes an available mode for the  key. An entry followed by  or  changes targ 1. Pressing  or  alone allows access to the subsets. PA 1 and PA 2 are the Fill subsets. The pre-acts can be deleted as subsets by choosing Disabled at P5114 and P5115. See *Changing Targets from the Weigh Mode (General)* on page 42 for detailed instructions on changing target values from the Weigh Mode.

EXAMPLE (FILL)

With a system set up to fill 55-gallon drums with motor oil, the following settings might be used to achieve an accurate final fill weight of 400 lbs.:

Parameter Setting	Actual Cutoff Value	Comments
Targ 1 = 400		Desired final weight.
Pre-act 1 = 28	$400 - 28 = 372.0$	Switch to dribble feed at 372.
Pre-act 2 = .5	$400 - 0.5 = 399.5$	Final fill valve closes at 399.5.

Batch

The standard batch program is used for batching up to three separate items. Ingredients 1 through 3 use setpoints and pre-acts 1 through 3 respectively. Ingredients are batched one at a time.

Table 8: Setpoint Setup (Batch)

Setpoint Selection	Function	Description
P5100.3	Batch	2 or 3 ingredient batching.
P5101.--	Targ1	Ingredient 1 target value.
P5104.0	Based	Select from <i>net</i> or <i>count (quantity)</i> .
P5105.--	PA 1	Pre-act 1 value (final cutoff for ingredient 1).
P5106.1	Learn 1	Learn feature for pre-act 1 enabled.
P5107.0	Start 1	Setpoint 1 activation method.
P5108.--	Targ 2	Ingredient 2 target value.
P5109.--	PA 2	Pre-act 2 value (final cutoff for ingredient 2).
P5110.1	Learn 2	Learn feature for pre-act 2 enabled.
P5111.0	Start 2	Setpoint 2 activation method.
P5116.1	Pause	Keypad press invokes pause mode.
P5117.--	Targ 3	Ingredient 3 target value.

Setpoint Selection	Function	Description
P5118.--	PrAc 3	Pre-act 3 value (final cutoff for ingredient 3).
P5119.1	Learn 3	Learn feature for pre-act 3 enabled.
P5120.0	Start 3	Setpoint 3 activation method.

See *Key-In Parameters* on page 21 for instructions on using front panel keys for entering data.

ACTIVATION METHOD (BATCH)

The filling of each ingredient begins when one of three selectable start functions occur. Each ingredient may have its own start function. The deactivation of the setpoint is automatic. The desired targets may be based on net weight or quantity (if counting is enabled). All ingredients must be based on the same parameter. See *Activation Methods (General)* on page 40 for details on activation methods.

Batch Status	Annunciator Status	Setpoint Status (Requires Setpoint Option Board)
Fill 1	SP 1 Illuminated	Relay 1 Contacts Closed, Relay 2 and 3 Contacts Open
Fill 2	SP 2 Illuminated	Relay 2 Contacts Closed, Relay 1 and 3 Contacts Open
Fill 3	SP 3 Illuminated	Relay 3 Contacts Closed, Relay 1 and 2 Contacts Open

PRE-ACTS (BATCH)

Pre-acts 1, 2 and 3 specify the final cutoff for each respective ingredient. See *Per-acts (General)* on page 41 for pre-act details.





LEARN FEATURE (BATCH)

Each batch pre-act has the learn feature available which allows the indicator to automatically adjust the final cutoff based on changing environmental conditions. See *Learn Feature (General)* on page 41 for ‘learn’ feature details.

PAUSE FEATURE (BATCH)

The standard pause feature (keypress, remote key closure or both) is available for the batch operation. See *Pause Feature (General)* on page 41 for ‘pause’ details.

CHANGING TARGETS FROM THE WEIGH MODE (BATCH)

When Batch is configured in the setpoint setup, Targ 1, 2 and 3 automatically become available modes for the  key. A keyed in entry followed by  or  changes the value of current target. Pressing  or  alone allows access to the subsets of the currently viewed target. PA 1, 2 and 3 are the respective subsets for Targ 1, 2 and 3. See *Changing Targets from the Weigh Mode (General)* on page 42 for detailed instructions on changing target values from the Weigh Mode.



Pre-acts 1 and 2 are *always* available as subsets of their respective targets from the Weigh Mode.

EXAMPLE (BATCH)

With a system set up a system to make a 50,000 lb batch with water (30,000 lbs.), corn syrup (15,000 lbs.) and caramel color (5,000 lbs.), ingredient 1 should start with  and subsequent ingredients should auto-start.

Parameter Setting	Actual Cutoff Value	Comments
Target 1 = 30,000		Desired water weight.
Based = Net		Targets are compared to net weight.
Pre-Act 1 = 100	$30,000 - 100 = 29,900$	Water valve closes at 29,900 lbs. Free-fall will bring weight to 30,000.
Learn 1 = Enabled		Analyze previous five fills and auto-adjust pre-act 1.
Start 1 = Tare		Start water with [TARE].
Target 2 = 15,000		Desired corn syrup weight.
Pre-Act 2 = 236	$15,000 - 236 = 14,764$	Corn syrup valve closes at 14,764 lbs. Free-fall will bring weight to 15,000.
Learn 2 = Enabled		Analyze previous five fills and auto-adjust pre-act 2.
Start 2 = Auto	Calculated cutoff value for corn syrup is added to current displayed weight	Start corn syrup when water is done and motion has stopped.
Target 3 = 5,000		Desired caramel coloring weight.
Pre-Act 3 = 142	$5,000 - 142 = 4,858$	Carmel coloring valve closes at 4,858. Free-fall will bring weight to 5,000.
Learn 3 = Enabled		Analyze previous five fills and auto-adjust pre-act 3.
Start 3 = Auto	Calculated cutoff value for carmel coloring is added to current displayed weight	Start carmel coloring when corn syrup is done and motion has ceased.
Pause = Keypad		Keypress will pause batch operation.

Discharge

The discharge program is designed for single-speed or dual-speed dispensing of product from a larger weigh vessel. Discharge is a loss-in-weight application similar in operation to the fill program. When a discharge is initiated, the scale automatically tares and comes to a net zero weight. The appropriate setpoints are activated and material is discharged until the decreasing net weight reaches the desired target value.

Table 9: Setpoint Setup (Discharge)

Setpoint Selection	Function	Description
P5100.1	Discharge	Select discharge setpoint operation.
P5101.--	Targ1	Final dispensed target value.
P5104.0	Based	Select between net or count (quantity)
P5105.--	PA 1	Pre-act 1 value (fast-to-slow value; 0 for single-speed).
P5107.0	Start 1	Setpoint activation method.
P5109.--	PA 2	Pre-act 2 value (final cutoff).
P5110.1	Learn 2	Learn feature for pre-act 2.
P5114.1	PrAc 1	Pre-act 1 available as subset in Weigh Mode.
P5115.1	PrAc 2	Pre-act 2 available as subset in Weigh Mode.
P5116.1	Pause	Keypress invokes pause.

See *Key-In Parameters* on page 21 for instructions on using front panel keys for entering data.

ACTIVATION METHOD (DISCHARGE)

The dispensing activation is limited to  or a remote key input. The deactivation of the setpoints is automatic. The desired target may be based on net or quantity (if counting is enabled). See *Activation Methods (General)* on page 40 for activation details.

Discharge Status	Annunciator Status	Setpoint Status (Requires Setpoint Option Board)
Fast Discharge	SP 1 & SP 2 Illuminated	Relay 1 and 2 Contacts Closed
Slow (or Single-Speed) Discharge	SP 1 Illuminated	Relay 1 Contacts Closed
Fill Done or Pause	SP 1 & 2 Off	Relay 1 and 2 Contacts Open

PRE-ACTS (DISCHARGE)

Pre-act 1 is used for dual-speed dispensing. Pre-act 1 specifies when the system should switch from fast-discharge to slow-discharge. When using a single-speed device, pre-act 1 should be set to 0 from the Setup Mode. P5114 should also be disabled to prevent pre-act 1 from appearing as a subset of the target in the Weigh Mode. Pre-act 2 specifies the point where the final cutoff should occur, regardless of a single-speed or dual-speed operation. See *Pre-acts (General)* on page 41 for details on the operational functions of pre-acts.



Pre-act 1 controls setpoint 2. Pre-act 2 controls setpoint 1.





LEARN FEATURE (DISCHARGE)

Pre-act 2 has the learn feature available which allows the indicator to automatically adjust the final cutoff based on changing environmental conditions. See *Learn Feature (General)* on page 41 for learn feature details.

PAUSE FEATURE (DISCHARGE)

The standard pause feature (keypress, remote key closure or both) is available for the discharge operation. See *Pause Feature (General)* on page 41 for pause function details.

TARGET CHANGES FROM THE WEIGH MODE (DISCHARGE)

When Discharge is configured in the setpoint setup, Targ 1 automatically becomes an available mode for the  key. An entry followed by  or  changes Targ 1. Pressing  or  alone allows access to the subsets. PA 1 and PA 2 are the subsets for Targ 1. The pre-acts can be deleted as subsets by choosing ‘disabled’ at P5114 and P5115. See *Changing Targets from the Weigh Mode (General)* on page 42 for instructions on changing target values from the Weigh Mode.





Target and pre-act values are entered as positive values.

If the total amount of product in the weigh vessel is less than the entered target, the indicator will prompt **Tare ~ =Cont**. Pressing  will dispense whatever is left in the vessel. Pressing any other key will abort the discharge cycle to allow for refilling the vessel.

EXAMPLE (DISCHARGE)

With a system set up to dispense ball bearings from a 50,000 lb weigh-bin and the fast-feed requiring an early cutoff to slow-feed, the following settings might be used to achieve accurate dispensing of 1000 bearings:

Parameter Setting	Actual Cutoff Value	Comments
Targ 1 = 1000	0 – 1000 = (-1000)	Desired quantity (decreasing value from a net zero: enter as a positive value).
Based = Qty		Targets are compared to quantity (P170 Enabled).
PA 1 = 200	1000 – 200 = 800 0 – 800 = (-800)	Switch to slow feed at –800 bearings (decreasing value from a net zero: enter as a positive value).
Start = 		Start discharge with  .
PA 2 = 15	1000 – 15 = 985 0 – 985 = (-985)	Final gate begins closing at 985 bearings. Delayed closure brings final quantity to 1000 (decreasing value from a net zero: enter as a positive value).
Learn 2 = Enabled		Analyze five previous operations and auto-adjust Pre-Act 2.
PrAc 1 = Enabled		Pre-act 1 available as subset of Targ 1 in Weigh Mode.
PrAc 2 = Disabled		Pre-act 2 NOT available as subset of Targ 1 in Weigh Mode (auto-adjust only).
Pause – Remote		Remote key closure invokes Pause.

Both

The ‘Both’ program combines a fill operation with a discharge operation. This automates a single-speed vessel filling operation with a single-speed multiple dispensing function. Setpoint 1 is used for filling the

vessel and Setpoint 2 is used for product discharge. The ‘both’ program uses values for two targets and two pre-acts. Both targets must be based alike (net or quantity, quantity if count is selected).

Table 10: Setpoint Setup (Both)

Setpoint Selection	Function	Description
P5100.5	Both	Select both setpoint operation.
P5101.--	Targ1	Vessel fill target value.
P5104.0	Based	Select from <i>Net</i> or <i>Count (Quantity)</i> .
P5105.--	PA 1	Pre-act 1 value for vessel fill.
P5106.1	Learn 1	Learn feature for pre-act 1.
P5107.0	Start 1	Setpoint 1 activation method.
P5108.--	Targ 2	Vessel discharge target value.
P5109.--	PA 2	Pre-act 2 value for vessel discharge.
P5110.1	Learn 2	Learn feature for pre-act 2.
P5111.0	Start 2	Setpoint 2 activation method.
P5116.1	Pause	Keypad press invokes pause.

See *Key-In Parameters* on page 21 for instructions on using front panel keys for entering data.

ACTIVATION METHOD (BOTH)

The fill and discharge functions begin with their selected activation methods. The deactivation of the setpoints is automatic. The desired target may be based on net or quantity (if counting is enabled). See *Activation Methods (General)* on page 40 for activation details.

Both Status	Annunciator Status	Setpoint Status (Requires Setpoint Option Board)
Vessel Fill	SP 1 Illuminated	Relay 1 Contacts Closed
Vessel Discharge	SP 2 Illuminated	Relay 2 Contacts Closed
Fill Done or Pause	SP 1 & SP 2 Off	Relay 1 and Relay 2 Contacts Open

PRE-ACTS (BOTH)

Pre-act 1 is used for vessel filling. Pre-act 1 specifies the point where the final cutoff for the fill should occur. Pre-act 2 specifies the point where the final cutoff for the material discharge should occur. See *Pre-acts (General)* on page 41 for details on the operational functions of pre-acts.



Pre-act 1 controls setpoint 1. Pre-act 2 controls setpoint 2.





LEARN FEATURE (BOTH)

Both pre-act 1 and 2 have the learn feature available which allows the indicator to automatically adjust the final cutoff based on changing environmental conditions. See *Learn Feature (General)* on page 41 for ‘learn’ feature details.

PAUSE FEATURE (BOTH)

The standard pause feature (keypress, remote key closure or both) is available for the Both operation. See *Pause Feature (General)* on page 41 for ‘pause’ functions details.

TARGET CHANGES FROM THE WEIGH MODE (BOTH)

When Both is configured in the setpoint setup, Targ 1 and Targ 2 automatically become available modes for the  key. An entry followed by  or  changes the currently viewed target. Pressing  or  alone allows access to the subsets. PA 1 is the subset for Targ 1 and PA 2 is the subset for Targ 2.





Pre-acts 1 and 2 are always available as subsets of their respective targets from the Weigh Mode.

Since the discharge portion of the Both cycle is a loss-in-weight operation, target 2 and pre-act 2 entries are entered as positive values and interpreted by the indicator as negative. See *Changing Targets from the Weigh Mode (General)* on page 42 for detailed instructions on changing target values from the Weigh Mode.

EXAMPLE (BOTH)

With a system set up to fill a weigh vessel with 2000 lbs. of paint and to meter out the paint in 45 lb buckets, the following settings might be used:

Parameter Setting	Actual Cutoff Value	Comments
Targ 1 = 2000		Desired vessel fill target.
Based = Net		Targets are compared to net weight.
PA 1 = 5	$2000 - 5 = 1995$	Fill valve closes at 1995 lbs.
Learn 1 = Enabled		Analyze five previous fills and auto-adjust pre-act 1.
Start 1 = R-but		Start fill with remote key closure.
Targ 2 = 45	$0 - 45 = (-45)$	Desired discharge target (decreasing weight from a net zero: enter as a positive value).
PA 2 = 5	$45 - 5 = 40$ $0 - 40 = (-40)$	Discharge valve closes at (-40) lbs. (decreasing weight from a net zero: enter as a positive value).
Learn 2 = Enabled		Analyze five previous discharges and auto-adjust pre-act 2.
Start 2 = 		Start discharge with 
Pause = None		Disable pause function.

Absolute Check-Weighing

This program is commonly used for check-weigh applications. After a target weight is entered, upper and lower tolerances are entered as absolute values. Over and Under tolerances are also entered as absolute values. The desired target may be based on gross weight, net weight, or quantity (if counting is enabled). Only the annunciators will light to indicator the setpoint status. Physical setpoints cannot be added at this time. The setpoint modules will be available in the near future and will be installed in a safe area hub.

Table 11: Setpoint Setup (Absolute Check-Weighing)

Setpoint Selection	Function	Description
P5100.6	ChecA	Check-weigh by absolute value.
P5101.--	Targ1	Absolute target value.
P5102.--	Lo	Low acceptance value.
P5103.--	Hi	High acceptance value.
P5104.0	Based	Select from <i>Net</i> , <i>Gross</i> or <i>Count (Quantity)</i> .

See *Key-In Parameters* on page 21 for instructions on using front panel keys for entering data.

SETPOINT ACTIVATION (ABSOLUTE CHECK-WEIGHING)

In order for the annunciators or setpoints to activate, the displayed value must be at least five graduations above zero. A setpoint option board may be installed to allow the M350 to directly control lights, buzzers, drop-gates, or reject devices.

Check-Weigh Status	Annunciator Status	Annunciator Color (LED)
OVER	SP 1 Illuminated	Red
GOOD	SP 2 Illuminated	Green
UNDER	SP 3 Illuminated	Yellow



The Pre-Acts, Learn Mode, and Pause Feature options are not applicable to check-weigh operation.

CHANGING TARGETS FROM THE WEIGH MODE (ABSOLUTE CHECK-WEIGHING)

When Check-Weigh by Absolute is configured in the setpoint setup, the Targ 1 value automatically becomes an available mode for the key. It is possible to accept the applied weight as the target. Instead of keying in the target value from Targ 1, press (350 IS) or (355 IS). Press (350 IS) or (355 IS) again to accept the target.

To change targets from the Weigh Mode (350 IS):

1. Press .
DISPLAY READS ►0.00
2. Press to view the current fill target.
DISPLAY READS ►Targ1 ~ 250
3. Press **400** to set a new fill target of 400 lbs.
DISPLAY READS ►Targ1 ~ 400
4. Press to select the Pre-Act 1 (subset) value of 28 lbs.
DISPLAY READS ►PA 1 ~ 28

5. Press  to select the Pre-Act 2 (subset) value of 1.5 lbs.

DISPLAY READS ►PA 2 ~ 1.5

6. Press **.5**  to select a new Pre-Act 2 value of .5 lbs.

DISPLAY READS ►PA 2 ~ .5





7. Press  to display the current Gross Weight.

DISPLAY READS ►15.12

To change targets from the Weigh Mode (355 IS):

1. Press  to view the current fill target.

DISPLAY READS ►Targ1 ~ 250

2. Key in the new target value and press . Example    .

DISPLAY READS ►Targ1 ~ 100

EXAMPLE (ABSOLUTE CHECK-WEIGHING)

With a system set up to check-weigh 50 lb. cement bags, the following settings might be used check-weigh bag from 49.5 to 51.5 lbs.:

Parameter Setting	Acceptable Check-Weigh Values	Comments
Target = 50.00		Desired bag weight.
Low Value = 49.50	49.50 – 50.00 lbs.	Low acceptable range = 49.50 to 50.00 lbs.
High Value = 51.50	50.00 – 51.50 lbs.	High acceptable range = 50.00 to 51.50 lbs.

Independent Setpoint Operation

Independent Setpoints allow controlling setpoints when the gross, net or quantity (if counting is enabled) is above or below a target value. The reset (deactivation) choice of each setpoint is selectable from *Tare*, *Remote Key*, *Auto*, *Non-latching* or *Absolute*. See *Key-In Parameters* on page 21 for instructions on using front panel keys for data entry.

Table 12: Setpoint Setup (Independent)

Setpoint Selection	Function	Description
P5100.7	Indep	Independent Setpoints.
P5121.1	Base 1	Select from <i>Net</i> , <i>Gross</i> or Count (<i>Quantity</i>) for setpoint 1.
P5122.0	Act 1	Activate setpoint 1 when weight is above or below.
P5123.--	Targ 1	Setpoint 1 target for weight to either rise above or fall below.
P5124.0	Stbl 1	Setpoint 1 activation stability setting.
P5125.0	Rset 1	Reset selection for setpoint 1.
P5126.--	Rtrg 1	Value for reset. *Only available if “Value” is selected for Reset 1.
P5127.1	Rstb 1	Reset 1 stability setting.

Setpoint Selection	Function	Description
P5131.1	Base 2	Select from <i>Net</i> , <i>Gross</i> or <i>Count (Quantity)</i> for Setpoint 2.
P5132.0	Act 2	Activate setpoint 2 when weight is above or below.
P5133.--	Targ 2	Setpoint 2 target for weight to either rise above or fall below.
P5134.0	Stbl 2	Setpoint 2 stability setting.
P5135.0	Rset 2	Reset selection for setpoint 2.
P5136.--	Rtrg 2	Value for reset. *Only available if “Value” is selected for Reset 2.
P5137.1	Rstb 2	Reset 2 stability setting.
P5141.1	Base 3	Select from <i>Net</i> , <i>Gross</i> or <i>Count (Quantity)</i> for Setpoint 3.
P5142.0	Act 3	Activate setpoint 3 when weight is above or below.
P5143.--	Targ 3	Setpoint 3 target for weight to either rise above or fall below.
P5144.0	Stbl 3	Setpoint 3 stability setting.
P5145.0	Rset 3	Reset selection for setpoint 3.
P5146.--	Rtrg 3	Value for reset. *Only available if “Value” is selected for Reset 3.
P5147.1	Rstb 3	Reset 3 stability setting.

SETPOINT ACTIVATION (INDEPENDENT)

Independent Setpoints can be activated when either the gross weight, net weight or quantity (if counting is enabled) is above or below a target value. When an independent setpoint is set to Activate Above, the setpoint will activate when the selected mode (gross, net or quantity) is equal to or above the target. When set to Activate Below, the selected mode must actually be below the target.



A setpoint option board may be installed to allow the M350 to directly control lights, buzzers, valves or relays. Also, the setpoints can be configured to ignore or heed the stability setting (**P114**).

Independent Status	Annunciator Status	Setpoint Status (Requires Setpoint Option Board)
Setpoint 1 Active	SP 1 Illuminated	Relay 1 Closed
Setpoint 2 Active	SP 2 Illuminated	Relay 2 Closed
Setpoint 3 Active	SP 3 Illuminated	Relay 3 Closed

Independent Setpoint Reset (deactivation) choices:



Parameter Setting	Reset Choice	Description
P51x5.0	Tare	Setpoint deactivates with .
P51x5.1	Remote Key	Setpoint deactivates with Remote Key closure.
P51x5.2	Auto	Setpoint deactivates when weight returns to +/- 5 graduations of zero and stabilizes.
P51x5.3	Non-Latched	Setpoint deactivates when weight value is in a range opposite of the activation setting.
P51x5.4	Reset Value	Setpoint deactivates when weigh reaches a second value and stabilizes.



The Pre-Acts, Learn Mode, and Pause Feature options are not applicable to Independent Setpoint operation.

CHANGING TARGETS FROM THE WEIGH MODE (INDEPENDENT)

When Independent Setpoints are configured in the setpoint setup, Targ 1, 2 and 3 automatically become available modes for the key. An entry followed by or changes the currently viewed target. If

the reset for a setpoint is set to 'value', then pressing  or  alone will allow access to the subset of the target. Rtrg 1, 2 and 3 are the respective subsets for Targ 1, 2 and 3. See *Changing Targets from the Weigh Mode (General)* on page 42 for detailed instructions on changing target values from the Weigh Mode.

EXAMPLE (INDEPENDENT)

Setup a continuous-cycle static weighing system that fills a weigh hopper from a storage bin. The weigh hopper should stop the fill at a predetermined target, dump the product into a bag, and then restart the fill. A warning light should come on to give an operator advance notice to change the bag. The following setup might be used to achieve 1000 lb dumps:

Parameter Setting	Description
<i>P5121.1 ~ Base 1 ~ Net</i>	Weigh hopper dump valve based on net weight.
<i>P5122.0 ~ Act 1 ~ HI</i>	Hopper dump valve opens when net weight rises above target 1.
<i>P5123.-- ~ Targ 1 ~ 1000</i>	Target 1 value = 1000 kg.
<i>P5124.1 ~ Stbl 1 ~ Inhib</i>	Hopper dump valve delayed until scale is stable.
<i>P5125.2 ~ Rset 1 ~ Auto</i>	Dump valve auto-closes when net is within +/- 5 grads of zero and stable.
<i>P5127.1 ~ Rstb1 ~ Inhib</i>	Dump valve closure delayed until scale is stable.
<i>P5131.1 ~ Base2 ~ Net</i>	Weigh hopper fill valve based on net weight.
<i>P5132.1 ~ Act 2 ~ Under</i>	Fill valve opens when net weight falls below target 2.
<i>P5133.-- ~ Targ 2 ~ =100</i>	Target 2 value = 100 kg.
<i>P5134.1 ~ Stbl2 ~ =Inhib</i>	Fill valve opening delayed until scale is stable.
<i>P5135.4 ~ Rset 2 ~ =Targ</i>	Fill valve closes when net weight reaches reset target 2.
<i>P5136.-- ~ Rtrg2 ~ 1000</i>	Reset target 2 = 1000 kg.
<i>P5137.0 ~ Rstb2 ~ Ignore</i>	Fill valve closes regardless of stability.
<i>P5141.1 ~ Base 3 ~ Net</i>	Alarm light relay based on net weight.
<i>P5142.0 ~ Act 3 ~ Above</i>	Alarm relay activates when net weight rises above target 3.
<i>P5143.-- ~ Targ 3 ~ =900</i>	Target 3 = 900 kg.
<i>P5144.0 ~ Stbl3 ~ Ignore</i>	Alarm relay activates regardless of scale stability.
<i>P5145.3 ~ Rset 3 ~ Non-L</i>	Alarm relay closes when net weight falls below target 3.
<i>P5147.0 ~ Rset3 ~ Ignore</i>	Alarm relay closes regardless of scale stability.

Target Deviation Check-Weighing

The target deviation method uses a target value in which the upper and lower tolerances are deviated from the target. The upper and lower tolerances are fixed values. The accept window is varied by adding the high tolerance to the target and subtracting the low tolerance from the target. This feature is commonly used in check-weigh applications. The desired target may be based on gross weight, net weight or quantity (if counting is enabled). Only the annunciators will light to indicator the setpoint status. Physical setpoints cannot be added at this time. The setpoint modules will be available in the near future and will be installed in a safe area hub.

Table 13: Setpoint Setup (Target Deviation Check-Weighing)

Setpoint Selection	Function	Description
P5100.8	Checb	Target Deviation Mode.
P5101.--	Targ1	Target value.
P5102.--	Lo	Low acceptance percentage.
P5103.--	Hi	High acceptance percentage.
P5104.0	Based	Select from <i>Net</i> , <i>Gross</i> or <i>Quantity</i> .

See *Key-In Parameters* on page 21 for instructions on using the front panel keys for entering data.

SETPOINT ACTIVATION (TARGET DEVIATION CHECK-WEIGHING)

In order for the annunciators to activate, the displayed value must be at least five graduations above zero.

Check-Weigh Status	Annunciator Status	Annunciator Color (LED)
OVER	SP 1 Illuminated	Red
GOOD	SP 2 Illuminated	Green
UNDER	SP 3 Illuminated	Yellow



The Pre-Acts, Learn Mode, and Pause Feature options are not applicable to check-weigh operation.

CHANGING TARGETS FROM THE WEIGH MODE (TARGET DEVIATION CHECK-WEIGHING)

When Check-Weigh by Absolute is configured in the setpoint setup, the Targ 1 value automatically becomes an available mode for the key. It is possible to accept the applied weight as the target. Instead of keying in the target value from Targ 1, press (350 IS) or (355 IS). Press (350 IS) or (355 IS) again to accept the target. Lo and Hi are the subsets for Targ 1. Lo and Hi are entered as actual values.

To change targets from the Weigh Mode (350 IS):

1. Press .
DISPLAY READS ►0.00
2. Press to view the current fill target.
DISPLAY READS ►Targ1 ~ 250
3. Press **400** to set a new fill target of 400 lbs.
DISPLAY READS ►Targ1 ~ 400
4. Press to select the Pre-Act 1 (subset) value of 28 lbs.
DISPLAY READS ►PA 1 ~ 28
5. Press to select the Pre-Act 2 (subset) value of 1.5 lbs.
DISPLAY READS ►PA 2 ~ 1.5
6. Press **.5** to select a new Pre-Act 2 value of .5 lbs.
DISPLAY READS ►PA 2 ~ .5





7. Press  to display the current Gross Weight.

DISPLAY READS ►15.12

To change targets from the Weigh Mode (355 IS):

1. Press  to view the current fill target.

DISPLAY READS ►Targ1 ~ 250

2. Key in the new target value and press . Example  .

DISPLAY READS ►Targ1 ~ 100

EXAMPLE (TARGET DEVIATION CHECK-WEIGHING)

With a system set up to check-weigh ice cream containers, the following settings might be used to guarantee container weights from 1.98 to 2.04 lbs.:

Parameter Setting	Acceptable Check-weigh Values	Comments
Target = 10.00		Desired container weight.
Lo Value = 0.5	$10.00 - 0.5 = 9.50$	Low acceptable range = 9.50 to 10.00
Hi Value = 0.25	$10.00 + 0.25 = 10.25$	High acceptable range = 10.00 to 10.25

Bargraph Setup (LCD)

A bargraph display is available for the ChecP and ChecA setpoint modes of operation. To enable the bargraph, refer to parameter P5011 (SPbar) in the *Parameter Map* section beginning on page 32. To weight each segment of the bargraph refer to parameter P5012 (bArPc) in the *Parameter Map* section beginning on page32.

SCALING FOR “BARS” (BARGRAPH ARROWS)

If the first bar turns off at the specified percentage (set at P5012) of the low limit, and the last bar turns off at the low limit, then the difference will be divided by 8 to determine the number of lbs per bar. At less than 5 grads, the entire graph is off.

Example#1: “ChecP” (refer to)

- Lower Limit is set at 50lbs.
- **P5012** is set for **80%**
- **(Bar weight = 50 – 40 = 10)**
(10/8 = 1.25 lbs)

NOTE: Right-side bars will have the same scaling (lb per bar) as the left-side bars. They are represented as a mirror image of each other.

<u>Bars ON</u>	<u>Weight Range (Lower Tolerance Limit)</u>
10	< 40
8	40.00 to 41.25
7	41.25 to 42.50

6	42.50 to 43.75
5	43.75 to 45.00
4	45.00 to 46.25
3	46.25 to 47.50
2	47.50 to 48.75
2	48.75 to 50.00

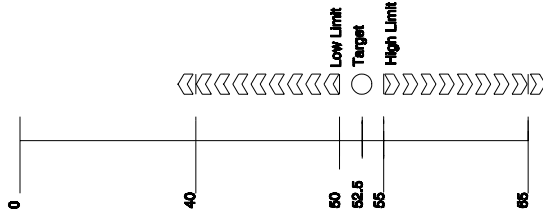

Figure 16: Example #1 Bargraph Segments (Weighted Value)

Example#2: : “ChecP” (refer to Figure 16)

- Lower Limit is set at 50lbs.
- **P5012** is set for **20%**
- (**Bar weight = 50 – 10 = 40**)
(40/8 = **5 lbs**)

NOTE: Right-side bars will have the same scaling (lb per bar) as the left-side bars. They are represented as a mirror image of each other.

<u>Bars ON</u>	<u>Weight Range (Lower Tolerance Limit)</u>
9	< 10
8	10.00 to 15.00
7	15.00 to 20.00
6	20.00 to 25.00
5	25.00 to 30.00
4	30.00 to 35.00
3	35.00 to 40.00

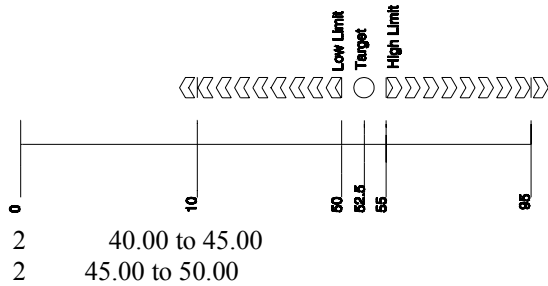

Figure 17: Example #2 Bargraph Segments (Weighted Value)

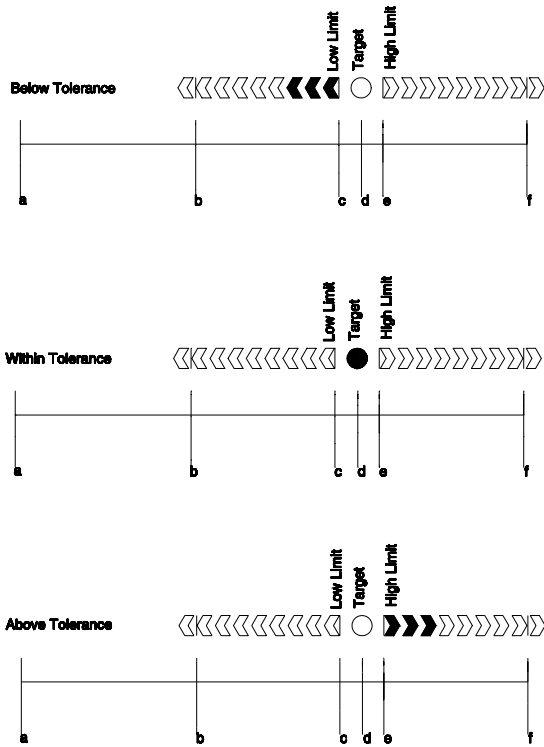

Figure 18: Examples of the Bargraph "Below, Within and Above Tolerance"

NOTE: (bargraph for filling and emptying modes)

For modes other than check-weighing, the bars will be on *only* while the setpoints are on and during the "Done" at the end of a fill.

The bar weights will be calculated similar to the check-weigh modes of operation stated above for filling, batching, etc., except that the percentage will be based on the actual target, rather than the low-limit value (see the equation below). The operation for emptying (and the emptying portion of 'both') will be the same except that the weight will be going negative while the left side bars are turning off.

$$\text{Bargraph segment weight} = \frac{100}{8.5} \left(\text{Target} - [(\% \text{ set at P5012}) \cdot \text{Target}] \right)$$



Although the setpoint annunciators are not motion-inhibited, the setpoint relay outputs will not activate until a no-motion condition exists.

Time and Date Setup (Model 350 IS)













The time and date feature is stored as non-volatile (time/date setting will not be lost when the unit power is reset). The time/date parameter is available in the first two fixed transmits (See *Transmit Selection on page 29*) and can be included in a custom transmit (See *Custom Transmit Setup on page*

32). The time and date can be accessed from the weigh mode with the  key if P502 is enabled.

Enter ~ Date~01.01.70. If the date is acceptable, press the .





To enter the date from the *Enter~date~01.01.70* prompt









EXAMPLE: 01.09.04 (January 9, 2004)

1. Press  to toggle through the numbers to enter the month.
DISPLAY READS ► 1
2. Press  twice to move the decimal point over to separate the month from the day. It is not necessary to enter a 0 before a single digit month. If it is a double-digit entry, press  once to move the cursor and then  to scroll through the digits.
DISPLAY READS ► 1.
3. Press  to toggle through the numbers to enter the day.
DISPLAY READS ► 1.9
4. Press  twice to move the decimal point over to separate the day from the year. It is not necessary to enter a 0 before a single digit month. If it is a double-digit entry, press  once to move the cursor and then  to scroll through the digits.
DISPLAY READS ► 1.9.
5. Press  to toggle through the numbers to enter the year.
DISPLAY READS ► 1.9.0
6. Press  once to move the cursor and then press  to scroll through the digits.
DISPLAY READS ► 1.9.04
7. Press  twice to accept the entry.
DISPLAY READS ► 01.09.04

To enter the time from the *Enter~time~00.00.00* prompt



EXAMPLE: 16.32.41 (4:32:41 P.M.)

1. Press  to toggle through the numbers to enter the hour. Hours must be entered as military time.
DISPLAY READS ► 1
2. Press  once to move the cursor. Press  to select the next digit.
DISPLAY READS ► 16
3. Press  twice to move the decimal point over to separate the hour from the minutes. It is not necessary to enter a 0 before a single digit hour.
DISPLAY READS ► 16.

4. Press  to toggle through the numbers to enter the minutes.
DISPLAY READS ► 16.3
5. Press  once to move the cursor. Press  to select the next digit.
DISPLAY READS ► 16.32
6. Press  twice to move the decimal point over to separate the minutes from the seconds.
DISPLAY READS ► 16.32.
7. Press  to toggle through the numbers to enter the seconds. The seconds do not have to be entered. Press  to bypass entering the seconds.
DISPLAY READS ► 16.32.4
8. Press  once to move the cursor. Press  to select the next digit.
DISPLAY READS ► 16.32.41
9. Press  twice to accept the time entry. The date and time are now saved until power to the indicator is lost. The display will be returned to the weigh mode.
DISPLAY READS ► 0.00







Time and Date Setup (Model 355 IS)

The time and date feature is stored as non-volatile (time/date setting will not be lost when the unit power is reset). The time/date parameter is available in the first two fixed transmits (*See Transmit Selection on page 29*) and can be included in a custom transmit (*See Custom Transmit Setup on page 32*).

The time and date can be accessed from the weigh mode with the  key if P502 is enabled. *Enter ~ Date~01.01.70*. If the date is acceptable, press the .









To enter the date from the *Enter~date~01.01.70* prompt



EXAMPLE: 01.09.04 (January 9, 2004)

1. Key in the date in the following format: 
DISPLAY READS ► 01.09.04
2. Press  to except the date.
3. Press  to move to the time entry.

To enter the time from the *Enter~time~00.00.00* prompt

EXAMPLE: 16.32.41 (4:32:41 P.M.)

1. Key in the date in the following format: 
DISPLAY READS ► 16.32.41

2. Press  to except the time
3. Press  to return to the weigh mode.

Remote Key Operation

The Model 350 and Model 355 IS has four selectable remote key operations to choose from: *Print*, *Tare*, *Zero* and *Print/Tare*. Only one of these operations may be assigned to the remote key input. Table 14 describes the available remote key operations. See *Remote Key Connection* on pages 15 for information on connecting a remote key input device.

Table 14: Remote Key Operations

Remote Key 1 and 2 Selections	Function	Description
P800.00 or P801.00	None	Remote key disabled.
P800.01 or P801.01	Print	Initiates print function. Print restrictions (P200 – P212) will be adhered to.
P800.02 or P801.02	Tare	Initiates tare function. Tare restrictions (P161 - P169) will be adhered to.
P800.03 or P801.03	Zero	Initiates zero function. Zero restrictions (P118) will be adhered to.
P800.04 or P801.04	Print and Tare	Initiates print function and then tare function. (P200 – P212) will be adhered to. Also (P161 - P169) will be adhered to.



Tare, Zero and Print functions will be delayed according to the stability setting (P114). If a setpoint operation is configured to use the remote key as an activation method, the P800 setting is over-ridden.

Remote Serial Operation

Table 15: Remote Serial Operation Remote Serial Operation

Command	ASCII	HEX	Description
Print	%p	F0h	Initiates print function. Print restrictions (P200 – P212) will be adhered to.
Select	%s	F3h	Performs a parameter or mode select operation.
Tare	%t	F4h	Initiates tare function. Tare restrictions (P161 - P169) will be adhered to.
Units	%u	F5h	Toggles between displayed units of measure.
Zero	%z	FAh	Initiates zero function. Zero restrictions (P118) will be adhered to.
Enter	%e	E5h	Enters preceding data into selected register. Also toggles through selections in Setup Mode.

Command	ASCII	HEX	Description
Piece Wt. Entry	%9	B9h	Allows a piece weight to be entered serially. For example, 0.10%9 will enter a piece weight of 0.10.
Print	W<CR> or P<CR>	57h, 0Dh	Initiates print function. Print restrictions (P200-P212) will be adhered to. Requires both hex values, 57h followed by 0Dh.
Zero	Z<CR>	5Ah, 0Dh	Initiates zero function. Zero restrictions (118) will be adhered to. Requires both hex values, 5Ah followed by 0Dh.

<CR> is a carriage return, decimal value 013, hex value 0Dh.

DISPLAY CAPTURE UTILITY

The Display Capture Utility sends the current display information out of the comm port when the extended ASCII character represented by decimal 149 (hex: 95h) is received through the comm port. Entering a decimal 149 from a computer keyboard can be accomplished by turning on the Num Lock and holding down the ALT key while typing the desired decimal number on the keyboard keypad (for example, <Alt>149).



The Display Capture Utility must have NTEP disabled in order to function.

EXAMPLE #1

The scale is in the weigh mode with the gross weight displayed (for example, 15.00).

Input: The extended ASCII character represented by decimal 149 (hex: 95h) is received through the comm port.

Output: “15.00 lb Gross ” is sent out the comm port.

EXAMPLE #2

The scale is in setup at P110 Full Scale.

Input: The extended ASCII character represented by decimal 149 (hex: 95h) is received through the comm port.







Output: “P110 F.S. 100.00 ” is sent out the comm port.

Upgrade Indicator Firmware

The Model 350 IS and Model 355 IS have flash memory on the main board where the parameters are stored. It is possible to update the firmware simply by using a computer. The firmware is loaded into a flash memory IC. This allows for ease in loading firmware updates.

PREPARE FOR UPGRADE

Before the indicator firmware can be updated, the procedure below must be followed. A computer with a serial port or USB port is required for loading a flash file. If you are using a USB port, a USB to serial converter is necessary.

1. Connect the communication cable from the computer to comm. 1 of the Model 350 IS or Model 355 IS.
2. Open a communications program or terminal window program (such as Communication Plus) on the computer.
3. Set the protocol of the indicator to be 9600 baud, 1 stop bit, no parity.
4. Go to parameter 65020 (re-flash) and press  (350 IS) or  (355 IS). Press  (350 IS) or  (355 IS) at the “ARE YOU SURE ? prompt. Press  (350 IS) or  (355 IS) at the Enter = Flash prompt.
5. The terminal program should show:
GSE Scale Systems
Division of SPX
300 Series Bootloader Version **XX** (*where XX should be at least 03*)
Date (*where Date should be at least Feb 2004*)
 - a) Erase Flash
 - b) Program Flash
 - c) Set Baud Rate
 - d) Quit
6. Typically the default baud rate on the computer will be 9600. The programming time at 9600 baud is about 6 minutes. At 38400 baud the programming time is about one minute and a half. At 57600 baud the programming time is about one minute. Set the computer baud rate in the terminal software to the desired baud rate by entering **c** from the computer keyboard.

LOAD FLASH FILE



1. The current flash file must be erased. Enter an **a** from the computer keyboard. When finished the menu choices will be replicated.
2. To program flash, enter a **b** from the computer keyboard. Open the flash file from your terminal window and send it to the indicator. After the file loads the menu choices will be replicated.
3. To end the flash process, enter a **d** from the computer keyboard to quit. The indicator will restart.

CHAPTER 4: CALIBRATION

Setup Mode Calibration

You can enter the Calibration Mode after accessing the Setup Mode to view and/or change parameter settings (see *Setup Mode* on page 18).







To access the Calibration Mode when viewing any setup parameter:

1. From the Setup Mode, press .
DISPLAY READS ► *Enter ~ =Cal!*
2. Press  or .
DISPLAY READS ► *First ~ Zero? ~ -0.26*











Fast Calibration

Fast Calibration allows calibration of the Model 350/355 IS scale system without accessing the Setup Mode.

To access Fast Calibration from the Weigh Mode (350 IS):

1. From the Weigh Mode, press  + .
DISPLAY READS ► *Setup~Enter ~ Code!*
 2. Press  →  →  → .
- DISPLAY READS ► *Fast ~ Cal!~First ~ Zero? ~ -0.26***

To access Fast Calibration from the Weigh Mode (355 IS):

1. From the Weigh Mode key in  .
- DISPLAY READS ► *Setup~Enter ~ Code!***
2. Key in  .
- DISPLAY READS ► *Fast ~ Cal!~First ~ Zero? ~ -0.26***

Fast Calibration can also be accessed if the following data stream is received via the comm port:

```
100%s54321%e
```

Performing Calibration

Calibration always begins by establishing a zero (no-load) reference. A complete calibration also requires establishing a span (test load) reference. This section details various methods for obtaining zero and span references.



Press or during calibration to back up one step in the procedure.

Establishing Zero

The Model 350/355 IS provides five methods for obtaining a zero (no load) calibration reference, First Zero, Last Zero, False Zero, Only Zero, and Cal Reset.

To select a calibration method (350 IS):

1. Press + to display the calibration prompt.
2. Press → → → to access the Calibration Mode.
3. Press to scroll through the five selections.
4. Press to establish zero.

To select a calibration method (355 IS):





1. Press to display the calibration prompt.
2. Press to access the Calibration Mode.
3. Press to scroll through the five selections.
4. Press to establish zero.

FIRST ZERO











The most common zeroing procedure, First Zero is used to establish a new zero (no load) calibration reference before proceeding to span the Model 350/355 IS. Use this method for first-time calibration and complete recalibration.





First Zero Calibration Method Example (350 IS):

1. From the Weigh Mode, press + .
- DISPLAY READS ► Setup**
2. Press → → → .
- DISPLAY READS ► Fast ~ Cal~First ~ Zero? ~ -0.26**
3. Remove any load on the scale.
- DISPLAY READS ► First ~ Zero? ~ -0.42**
4. Press to establish zero.

- DISPLAY READS ► 0.00**
5. Pause for motion delay.
DISPLAY READS ► Enter ~ Load ~ 0.00
 6. Place a 100lb test weight on scale.
DISPLAY READS ► Enter ~ Load ~ 99.66
 7. Enter 100.
DISPLAY READS ► 100
 8. Press  to establish span.
DISPLAY READS ► 100.00
 9. Pause for motion delay.
DISPLAY READS ► Cal ~ Good? ~ 100.00
 10. Press  to accept calibration.
DISPLAY READS ► Enter ~ =Stor
 11. Press  to save calibration.
DISPLAY READS ► Enter ~ =End
 12. Press  to exit calibration.
DISPLAY READS ► 100.00
 13. Remove the calibration weight.
DISPLAY READS ► 0.00

First Zero Calibration Method Example (355 IS):

1. From the Weigh Mode key in    .
- DISPLAY READS ► Setup**
2. Key in      .
- DISPLAY READS ► Fast ~ Cal~First ~ Zero? ~ -0.26**
3. Remove any load on the scale.
DISPLAY READS ► First ~ Zero? ~ -0.42
4. Press  to establish zero.
DISPLAY READS ► 0.00
5. Pause for motion delay.
DISPLAY READS ► Enter ~ Load ~ 0.00
6. Place a 100lb test weight on scale.
DISPLAY READS ► Enter ~ Load ~ 99.66
7. Enter 100.
DISPLAY READS ► 100

8. Press  to establish span.
DISPLAY READS ► 100.00
9. Pause for motion delay.
DISPLAY READS ► Cal ~ Good? ~ 100.00
10. Press  to accept calibration.
DISPLAY READS ► Enter ~ =Stor
11. Press  to save calibration.
DISPLAY READS ► Enter ~ =End
12. Press  to exit calibration.
DISPLAY READS ► 100.00
13. Remove the calibration weight.
DISPLAY READS ► 0.00









LAST ZERO





The Last Zero procedure allows recalibration of the weighing device using an existing test load. This is especially beneficial when checking high capacity applications such as tank weighing to minimize the task of placing and removing test weights.

















Establish gross zero *before* entering setup or calibration!



Last Zero Calibration With Weight Already Applied Example (350 IS):

1. Remove any load on the scale.
DISPLAY READS ► 10.
2. Press  to zero the scale.
DISPLAY READS ► 00.
3. Apply a 10000 lb test weight to verify calibration.
DISPLAY READS ► 9970.
4. Press  + .
- DISPLAY READS ► Setup**
5. Press  →  →  → .
- DISPLAY READS ► Fast ~ Cal~First ~ Zero? ~ 9930.**
6. Press .
- DISPLAY READS ► Last ~ Zero? ~9930.**
7. Press  to use last zero.

- DISPLAY READS ► *Enter ~ Load? ~ 9970.***
8. Enter 10000.
DISPLAY READS ► 10000
 9. Press  to establish span.
DISPLAY READS ► 10000.
 10. Pause for motion delay.
DISPLAY READS ► *Cal ~ Good? ~ 10000.*
 11. Press  to accept calibration.
DISPLAY READS ► *Enter ~ =Stor*
 12. Press  to save calibration.
DISPLAY READS ► *Enter ~ =End*
 13. Press  to exit calibration.
DISPLAY READS ► 10000.
 14. Remove the calibration weight.
DISPLAY READS ► 0.

Last Zero Calibration With Weight Already Applied Example (355 IS):











1. Remove any load on the scale.
DISPLAY READS ► 10.
2. Press  to zero the scale.
DISPLAY READS ► 00.
3. Apply a 10000 lb test weight to verify calibration.
DISPLAY READS ► 9970.
4. Press    .
- DISPLAY READS ► *Setup***
5. Press      .
- DISPLAY READS ► *Fast ~ Cal~First ~ Zero? ~ 9930.***
6. Press .
- DISPLAY READS ► *Last ~ Zero? ~9930.***
7. Press  to use last zero.
DISPLAY READS ► *Enter ~ Load? ~ 9970.*
8. Enter 10000.
DISPLAY READS ► 10000
9. Press  to establish span.



- DISPLAY READS ► 10000.**
10. Pause for motion delay.
DISPLAY READS ► Cal ~ Good? ~ 10000.
11. Press  to accept calibration.
DISPLAY READS ► Enter ~ =Stor
12. Press  to save calibration.
DISPLAY READS ► Enter ~ =End
13. Press  to exit calibration.
DISPLAY READS ► 10000.
14. Remove the calibration weight.
DISPLAY READS ► 00.

FALSE ZERO

















False Zero calibrates the Model 350/355 IS without removing the current gross weight. This is particularly useful in tank weighing applications where it may be both time consuming and costly to completely empty the tank. This operation is achieved by establishing a false (temporary zero) zero reference. Test weights may then be added to verify calibration. The zero reference determined during the last calibration is not affected.

False Zero Calibration Without Removing Existing Load Example (350 IS):

1. Press  + .
- DISPLAY READS ► Setup**
2. Press  →  →  → .
- DISPLAY READS ► Fast ~ Cal~First ~ Zero? ~ 5075.**
3. Press  .
- DISPLAY READS ► False ~ Zero? ~5075.**
4. Press  to establish false (temporary) zero.
DISPLAY READS ► Units ~ =lb
5. Pause to display calibration units.
DISPLAY READS ► Enter ~ Load? ~ 00.
6. Place a 2500lb test weight on scale.
DISPLAY READS ► Enter ~ Load? ~ 2510.
7. Enter 2500.
DISPLAY READS ► 2500
8. Press  to establish span.
DISPLAY READS ► 2500.

9. Pause for motion delay.
DISPLAY READS ► *Cal ~ Good? ~ 2500.*
10. Press  to accept calibration.
DISPLAY READS ► *Enter ~ =Stor*
11. Press  to save calibration.
DISPLAY READS ► *Enter ~ =End*
12. Press  to exit calibration.
DISPLAY READS ► *5055.*
13. Remove the calibration weight.
DISPLAY READS ► *00.*

False Zero Calibration Without Removing Existing Load Example (355 IS):

1. Press    .
- DISPLAY READS ► *Setup***
2. Press      .
- DISPLAY READS ► *Fast ~ Cal~First ~ Zero? ~ 5075.***
3. Press  .
- DISPLAY READS ► *False ~ Zero? ~5075.***
4. Press  to establish false (temporary) zero.
DISPLAY READS ► *Units ~ =lb*
5. Pause to display calibration units.
DISPLAY READS ► *Enter ~ Load? ~ 00.*
6. Place a 2500lb test weight on scale.
DISPLAY READS ► *Enter ~ Load? ~ 2510.*
7. Enter 2500.
DISPLAY READS ► *2500*
8. Press  to establish span.
DISPLAY READS ► *2500.*
9. Pause for motion delay.
DISPLAY READS ► *Cal ~ Good? ~ 2500.*
10. Press  to accept calibration.
DISPLAY READS ► *Enter ~ =Stor*
11. Press  to save calibration.
DISPLAY READS ► *Enter ~ =End*

12. Press  to exit calibration.

DISPLAY READS ► 5055.

13. Remove the calibration weight.

DISPLAY READS ► 00.

ONLY ZERO

Only Zero is used to establish a new calibration zero without affecting the span. This is useful for correcting changes to the scale's dead load, for example adding safety rails to a truck scale platform.

Only Zero Calibration Example (350):

1. From the Weigh Mode, press  + .

DISPLAY READS ► Setup

2. Press  →  →  → .

DISPLAY READS ► Fast ~ Cal~First ~ Zero? ~2640.

3. Press   .

DISPLAY READS ► Only ~ Zero? ~ 2640.

4. Remove any load on the scale.

DISPLAY READS ► Only ~ Zero? ~ 2620.

5. Press  to establish zero.

DISPLAY READS ► 00.

6. Pause for motion delay.

DISPLAY READS ► Cal ~ Good? ~ 00.

7. Press  to accept calibration.

DISPLAY READS ► Enter ~ =Stor

8. Press  to save calibration.

DISPLAY READS ► Enter ~ =End

9. Press  to exit calibration.

DISPLAY READS ► 00.



Only Zero Calibration Example (355 IS):

1. From the Weigh Mode, press    .

DISPLAY READS ► Setup

2. Press      .

DISPLAY READS ► Fast ~ Cal~First ~ Zero? ~2640.

3. Press   .

DISPLAY READS ► *Only ~ Zero? ~ 2640.*

4. Remove any load on the scale.

DISPLAY READS ► *Only ~ Zero? ~ 2620.*

5. Press  to establish zero.

DISPLAY READS ► *00.*

6. Pause for motion delay.

DISPLAY READS ► *Cal ~ Good? ~ 00.*

7. Press  to accept calibration.

DISPLAY READS ► *Enter ~ =Stor*

8. Press  to save calibration.

DISPLAY READS ► *Enter ~ =End*

9. Press  to exit calibration.



DISPLAY READS ► *00.*

RESET CALIBRATION



Cal Reset may be necessary when an over-load or under-load condition exists, preventing the completion of the calibration process. Calibration Reset adjusts the zero and gain factors of the A/D amplifier to factory default values for maximum sensitivity.

After performing a calibration reset, a complete recalibration is required. The effects of a calibration reset do not take effect until the Model 350/355 is recalibrated and calibration information has been saved.







If **Code 02** (under-load) or **Code 03** (over-load) is displayed during calibration, press  or  to perform a calibration reset.

Reset Calibration Gain Factors Example (350 IS):

1. Press  + .

DISPLAY READS ► *Setup*

2. Press  →  →  → .

DISPLAY READS ► *Fast ~ Cal~First ~ Zero? ~ xx.xx*

3. Remove any load on the scale.

DISPLAY READS ► *First ~ Zero? ~ xx.xx*

4. Press  to establish zero.

DISPLAY READS ► *Enter ~ Load? ~ 0.00*

5. Place a 100lb test weight on scale.

DISPLAY READS ► Code03

6. Press .

DISPLAY READS ► First ~ Zero? ~ -0.26

7. Remove any load on the scale.

DISPLAY READS ► First ~ Zero? ~ -0.42

8. Press to establish zero.

DISPLAY READS ► 0.00

9. Pause for motion delay.

DISPLAY READS ► Enter ~ Load ~ 0.00

10. Place a 100lb test weight on scale.

DISPLAY READS ► Enter ~ Load ~ xx.xx

11. Enter 100 with the and keys.

DISPLAY READS ► 100

12. Press to establish span.

DISPLAY READS ► 100.00

13. Pause for motion delay.

DISPLAY READS ► Cal ~ Good? ~ 100.00

14. Press to accept calibration.

DISPLAY READS ► Enter ~ =Stor

15. Press to save calibration.

DISPLAY READS ► Enter ~ =End

16. Press to exit calibration.

DISPLAY READS ► 100.00

17. Remove the calibration weight.

DISPLAY READS ► 0.00

Reset Calibration Gain Factors Example (355 IS):

1. Press .

DISPLAY READS ► Setup









2. Press .

DISPLAY READS ► Fast ~ Cal~First ~ Zero? ~ xx.xx

3. Remove any load on the scale.



DISPLAY READS ► First ~ Zero? ~ xx.xx

4. Press to establish zero.

- DISPLAY READS ► *Enter ~ Load? ~ 0.00***
5. Place a 100lb test weight on scale.
DISPLAY READS ► *Code03*
 6. Press .
DISPLAY READS ► *First ~ Zero? ~ -0.26*
 7. Remove any load on the scale.
DISPLAY READS ► *First ~ Zero? ~ -0.42*
 8. Press  to establish zero.
DISPLAY READS ► *0.00*
 9. Pause for motion delay.
DISPLAY READS ► *Enter ~ Load ~ 0.00*
 10. Place a 100lb test weight on scale.
DISPLAY READS ► *Enter ~ Load ~ xx.xx*
 11. Enter .
DISPLAY READS ► *100*
 12. Press  to establish span.
DISPLAY READS ► *100.00*
 13. Pause for motion delay.
DISPLAY READS ► *Cal ~ Good? ~ 100.00*
 14. Press  to accept calibration.
Enter ~ =Stor
 15. Press  to save calibration.
DISPLAY READS ► *Enter ~ =End*
 16. Press  to exit calibration.
DISPLAY READS ► *100.00*
 17. Remove the calibration weight.
DISPLAY READS ► *0.00*

Establishing A Span

Once a zero reference has been established, the Model 350/355 IS displays ***Enter ~ Load*** and awaits the entry of a span (test load) value. This value may be entered before or after the test load has been applied.

If the calibration weight value was entered before applying the test weight, ***Add ~ Load*** is displayed indicating that the test weight should now be applied. Apply the test weight, press  or  and proceed to *Exiting Calibration* on page 38.

If it is necessary to repeat the calibration process, press **ZERO** at the *Cal ~ Good?* prompt and repeat the calibration process.

Establishing span with a 100lb test weight:

1. Place a 100lb test weight on scale.
DISPLAY READS ► Enter ~ Load ~ xx.xx
2. Enter 100.
DISPLAY READS ► 100
3. Press **ZERO CLR** or **SAMPLE ENTER** to establish span.
DISPLAY READS ► 100.00
4. Pause for motion delay.
DISPLAY READS ► Cal ~ Good? ~ 100.00

When making a significant change to the previous calibration, or when the calibration weight is less than 5% of full scale capacity, *ReCal ~ ???* will be displayed instead of *Cal ~ Good?* In this event it is recommended that the calibration be performed a second time. Press **TARE** or **SAMPLE ENTER** to recalibrate, or press **ZERO** to skip recalibration.

Exiting Calibration

Once zero and span have been established, the newly acquired calibration information must be saved to non-volatile memory before it will be realized in the Weigh Mode.

To exit and save calibration information:

1. Press **TARE** or **SAMPLE ENTER** to accept calibration.
DISPLAY READS ► Enter ~ =Stor
2. Press **TARE** or **SAMPLE ENTER** to save calibration.
DISPLAY READS ► Enter ~ =End
3. Press **TARE** or **SAMPLE ENTER** to exit calibration.
DISPLAY READS ► 100.00

To exit without saving calibration information:

1. Press **TARE** or **SAMPLE ENTER** to accept calibration.
DISPLAY READS ► Enter ~ =Stor
2. Press **ZERO**.
DISPLAY READS ► Enter ~ =Undo

3. Press  or .

DISPLAY READS ► *Enter ~ =End*

4. Press  or  to exit calibration.

DISPLAY READS ► *99.66*



When saving calibration, parameters changed in the Setup Mode are also saved with their new selections.

CHAPTER 5: LEGAL FOR TRADE

The Model 350/355 IS default parameter setup does not ensure compliance with legal-for-trade installations as mandated by local weights and measures authorities. This chapter contains information on NTEP and OIML regulations, sealing and audit trails, and other requirements.

Since legal-for-trade requirements may vary, you must ensure that the Model 350/355 IS is installed in accordance with all local regulations.

NTEP Requirements

The National Type Evaluation Program (NTEP) is a widely accepted weights and measures standard in the United States, with most states abiding by some or all of the NTEP requirements. A complete list of these regulations is available in the “Handbook 44” publication distributed by the National Institute of Standards and Technology (NIST). For more information, call (301) 975-3058, or visit <http://www.nist.gov>.



The Model 350/355 IS NTEP Certificate of Conformance (C.O.C.) is **pending**.

In order to configure the Model 350/355 IS to comply with NTEP requirements, parameter P440-rstrc (*restrict*) must be enabled. This ensures the following:

- Serial data will not be received while in the Setup Mode.
- Received alpha characters will not be displayed.
- Numeric tare entries cannot be received through the serial port.
- Pressing  with a gross weight of zero (0) will not automatically switch to the net mode.
- Negative tare values are not accepted.
- Tare rounding is enforced.
- When the tare value is zero, the net mode is not selectable.



If the counting feature is enabled, NTEP requires a label on the front of the indicator stating “*The counting feature is not legal for trade*”.

Where applicable, enabling the *restrict* parameter will over-ride the current setting of other parameters.

OIML Requirements

The International Organization of Legal Metrology is an inter-governmental body which harmonizes the national metrology regulations of its world wide members. A list of regulation publications may be obtained from the Bureau International de Métrologie Légale (BIML) in Paris, France.

In order to configure the Model 350 IS to comply with OIML requirements, parameter P410-Euro must be enabled. Doing so will ensure the following:

- An over-load condition will result when the gross weight exceeds nine graduations over the full scale capacity.
- Full scale capacity is always referenced from the last zero calibration reference, not the last zero acquired by pressing .

Most NTEP requirements will also apply. See the *Other Requirements* section below for additional considerations.

Other Requirements

Several parameters must be considered on an individual basis as their configuration may vary with different applications. These parameters include, but are not limited to:

Parameter	Description	COMMENT
P110	Full Scale Capacity	Verify proper scale capacity.
P111	Division Size	Verify that the maximum allowable number of scale divisions are not exceeded.
P112	Zero Track	Verify required selection.
P114	Stability	Verify required selection.
P118	Zero Range	Verify required selection.
P212	Print Stability	Verify required selection.

Sealing And Audit Trails

Most legal-for-trade installations will require the Model 350/355 IS to be sealed. A sealed indicator cannot be accessed for setup or calibration changes without breaking a physical seal or incrementing an event counter, thus providing evidence of tampering.

The Model 350/355 IS has two types of sealing provisions, a physical seal and a three event audit trail counter. Check with your local weights and measures authority to determine your requirements.

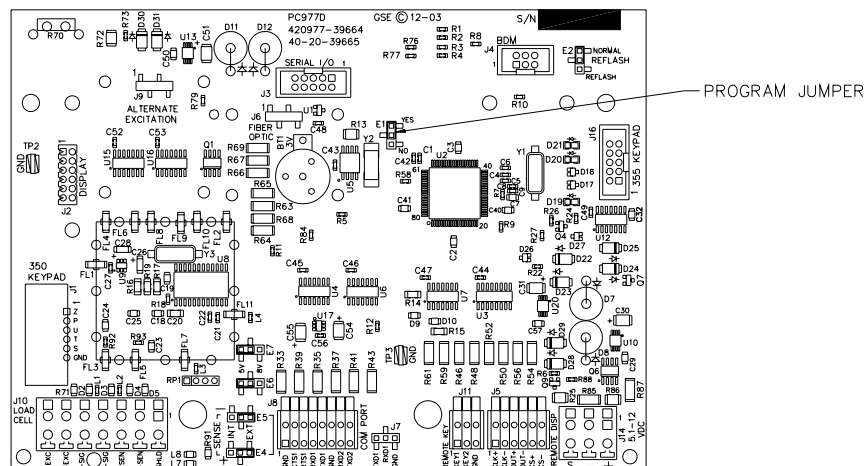

Figure 19: Model 350/355 IS Program Jumper (E1)

PHYSICAL SEAL

The most common sealing method is a lead-wire seal. The Model 350 IS and Model 355 IS provide an easy means of applying this type of seal as shown in Figure 20. Before applying a wire seal, move the program jumper to the 'NO' position as shown in Figure 19. This will prevent access to the Setup and Calibration Modes.

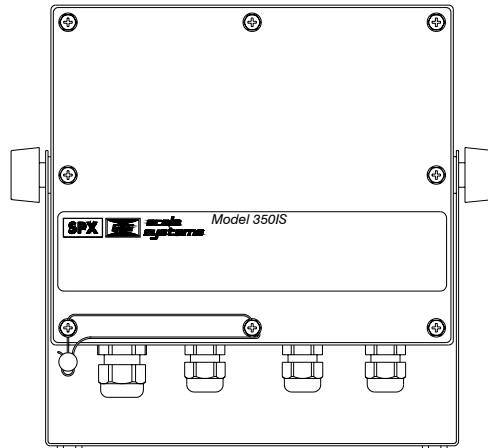

Figure 20: 350/355 IS Physical Seal

AUDIT TRAILS

Three separate incrementing, non-resetable audit trail parameters are used by the Model 350/355 IS to indicate changes to various parameters, P60201 – OIML, P60203 – Calibration, and P60204 – Setup. An audit trail counter will increment only once upon exiting the Setup Mode and saving changes regardless of how many settings were changed.

OIML AUDIT TRAIL

Changes to any of the following parameters will increment the OIML (Euro) audit trail at P60201:

- P110 – P118 (scale setup)
- P150 (default units)
- P151 (units enable)
- P410 (Euro enable)
- P440 (rStrc enable)
- Existing Calibration

CALIBRATION AUDIT TRAIL

Any changes to the existing calibration will increment the Calibration (CAL) audit trail at P60203.











SETUP AUDIT TRAIL

Changes to any of the Setup Mode parameters will increment the setup audit trail at P60204.













VIEWING AUDIT TRAIL PARAMETERS

Audit trail parameters may be viewed at any time.

To view audit trail parameters: (Model 350 IS)

1. Press  + .
DISPLAY READS ► Setup~Enter ~ Code!
2. Press  →  →  → .
DISPLAY READS ► -No- ~ Chgs!~P112 ~ FS ~ xx.xx
3. Enter [60203] with the  and  keys.
DISPLAY READS ► 60203
4. Press  to view the selected audit trail.
DISPLAY READS ► Audit ~ Trail~CAL. ~ 00001
5. Press  to return to the Weigh Mode.
DISPLAY READS ► 0.00

To view audit trail parameters: (Model 355 IS)

1. Press    .
DISPLAY READS ► Setup~Enter ~ Code!
2. Press      .
DISPLAY READS ► 60203
3. Press  to view the selected audit trail.
DISPLAY READS ► Audit ~ Trail~CAL. ~ 00001
4. Press  to return to the Weigh Mode.
DISPLAY READS ► 0.00

CHAPTER 7: TROUBLESHOOTING

This chapter contains error messages and information parameters, as well as information on setup parameter selections and A/D Calibration.

Error Messages

The Model 350/355 IS utilizes the following types of error messages: *Operational Errors*, *Setup Mode Errors*, *Hardware Errors*, *Calibration Errors*, *Communication Errors*, and *Miscellaneous Errors*.

OPERATIONAL ERRORS

<i>Code02</i>	Under Load. Input signal is less than negative full scale. Check load cell wiring. Verify correct capacity selection at P110.
<i>Code03</i>	Over Load. Input signal is greater than positive full scale. Use same checks as “under load” above.
<i>Funct ~ Disbl</i>	Attempted to perform a function disabled in the Setup Mode.
<i>Code 04</i>	The digits on the display have exceeded the six digit display capacity.
<i>Code 05</i>	Zero attempted beyond that allowed by P118.
<i>Code 08</i>	Input signal greatly exceeds the valid range. Check the load cell connection.
<i>Tare ~ Error</i>	Negative tare attempted when disabled (P440 enabled).
<i>Tare ~ GT FS</i>	Tare value greater than full scale capacity.
<i>Delay</i>	Indicates that a motion delay is in effect (zero, tare, etc.).
<i>Delay ~ Abort</i>	Acknowledges that a motion delayed function was aborted.
<i>Print ~ Abort</i>	Acknowledges that a motion delayed print request was aborted.
<i>Add ~ Load!</i>	If displayed after performing a count sample, this message indicates that a larger sample size is required.
<i>Out of ~ Range</i>	Attempted to enter a value beyond the allowable range.
<i>SPTxx ~ Error</i>	A conflict occurred with a setpoint value entry (example: target entry is less than preact). The digits ‘xx’ represent the last two digits of the setpoint parameter in error (example: <i>SPT 5 ~ Error</i> indicates a conflict at P5105, preact 1).

Need APS A setpoint *start* is initiated and the setpoint is based on *quantity* and no piece weight has been established (start will not occur).

SETUP MODE ERRORS

- Bad ~ Code!* An incorrect access code was entered.
- Unit ~ Seald* Access to the Setup or Calibration Mode was denied. Check the internal “YES/NO” program jumper.
- Unit3-Ntep Code 49.* Parameter 440 (NTEP) is enabled and parameter 152 (third unit) is set to an additional unit. The third unit is not NTEP approved.
- Entry ~ Error* An invalid entry was made.
- Need ~ Entry* A numeric value was required before pressing .
- Out of ~Range* The entered value exceeded the allowable range.
- Can't ~ Set!* Attempt to change a parameter that does not allow an entry.
- ResGT ~ 260E3 Code 35.* The number of divisions exceeds 260000 (see P110, P111).
- ResGT ~ 25E3* The number of divisions exceeds 25000 (see P110, P111).
- ResLT ~ 100!* The number of divisions is less than 100 (see P110, P111).
- ResLT ~ 1 !!* Number of divisions is less than one (see P110, P111).
- SPTxx ~ Error* A conflict occurred with a setpoint value entry (example: target entry is less than preact). **The digits ‘xx’ represent the last two digits of the setpoint parameter in error** (example: *SPT 5 ~ Error* indicates a conflict P5105, preact 1).
- Prtcl ~ Error* Existing protocol is invalid. The following are not allowed:
- P201 = 7 data bits, P202 = no parity, P203 = 1 stop bit
- P201 = 8 data bits, P202 = even parity, P203 = 2 stop bits
- P201 = 8 data bits, P202 = odd parity, P 203 = 2 stop bits

HARDWARE ERRORS



- Code00* An EPROM problem detected during power-up (U2).
A-D ~ Bad! Problem with A/D chip detected. Disconnect any options installed and re-power the unit. Options are connected to the same serial lines as the A/D so they may prevent it from working properly.
Or Code17
- Deflt ~ A-D* Bad A/D calibration values. Recalibrate A/D (see *A/D Calibration Procedure* on page 91).
- Re- ~ Boot!* EEPROM data could not be read. Attempting power-up reset.

<i>Chc ~ E2</i>	EEPROM data error (U4).
<i>Deflt ~ Setup</i>	An error occurred when reading setup data from the EEPROM during power-up. All parameters are set to factory default.
<i>Ch.XXXX</i>	A checksum error occurred during power-up. All annunciators are lit. The EPROM integrity test failed or is improperly seated.
<i>E2 ~ Full!</i>	The EEPROM setup exceeds the memory capacity.
<i>NoSpc ~ Free!</i>	The current setup exceeds the setup RAM capacity.

CALIBRATION ERRORS

<i>F.S. ~ TooHi</i>	The entered calibration weight will result in an over-capacity condition at full scale. Verify that the full scale (P110) and calibration weight value are correct.
<i>F.S. ~ TooLo</i>	The entered calibration weight will result in a full scale input signal less than the minimum allowed. Verify that the full scale (P110) and entered weight value are correct.
<i>Add ~ Load!</i>	The calibration weight is less than 0.1% of capacity. More weight is required.
<i>ReCal ~ ???</i>	Repeat the cal. procedure for accuracy. This prompt appears when the calibration weight is less than 5% of capacity, or when the A/D coarse gain is adjusted.
<i>Entry ~ Error</i>	An invalid entry was made.

COMMUNICATION ERRORS

<i>Par-Er</i>	The selected parity (P202) does not match that of the connected device.
<i>Buf-Er</i>	The receive buffers capacity was exceeded. This indicates a handshaking problem. Check P204 and verify proper communication port connections.
<i>Bit-Er</i>	The stop bit of a received character did not occur when expected. Verify that protocol (P200 – P204) matches that of the connected device.
<i>TrHold</i>	Data transmission is inhibited due to a deasserted handshake. Press  or  to abort transmission. Check P204.



MISCELLANEOUS ERRORS

<i>T.X.YYYY</i>	If catastrophic errors occur in the software, a trap error may occur and freeze the display with address information. (X = bank number and YYYY = the address of the trap error. Press any key five seconds after viewing message to reboot the unit).
-----------------	--





Viewing Setup

While troubleshooting it may be helpful to view the setup parameter selections. This can be done using the procedure below (even with the internal program jumper in the “NO” position). Note that accessing the Setup Mode in this manner will not permit parameter changes.

To view the setup parameter selections (350 IS):

1. From the Weigh Mode, press  + .
DISPLAY READS ► Setup~Enter ~ Code!
2. Press .
DISPLAY READS ► -No- ~ Chgs!~P110.-- ~ F.S.= ~ 100.0
3. Navigate the Setup Mode as described in *Setup Mode* on page 18 and 19.

To view the setup parameter selections (355 IS):

1. From the Weigh Mode, press    .
DISPLAY READS ► Setup~Enter ~ Code!
2. Press .
DISPLAY READS ► -No- ~ Chgs!~P110.-- ~ F.S.= ~ 100.0
3. Navigate the Setup Mode as described in *Setup Mode* on page 18 and 19.







To exit the Setup Mode:

1. Press .
2. Press .

Information Mode Parameters

A series of informational parameters are available beginning at P60000. These parameters may be accessed from the Setup Mode, or from the Weigh Mode as described below. Refer to Table 16 for an explanation of each information parameter.

To access the informational parameters (350 IS):

1. Press  + .
DISPLAY READS ► Setup~Enter ~ Code!
2. Press  →  →  → .
DISPLAY READS ► P60000 ~ E2Ins ~ 512
3. Navigate the Setup Mode as described in *Setup Mode* on page 18 and 19.

To access the informational parameters (355 IS):

4. Press **1 0 0** **SELECT**.

DISPLAY READS ► Setup~Enter ~ Code!

5. Press **6 0 0 0 0** **SAMPLE ENTER**.









DISPLAY READS ► P60000 ~ E2Ins ~ 512

6. Navigate the Setup Mode as described in *Setup Mode* on page 18 and 19.

As each information parameter is accessed, the parameter number is briefly displayed, followed by the parameter name, and finally the parameter value. To repeat the parameter number and name sequence, press **SELECT**. To exit the information mode, press **ZERO**.

Table 16: Information Parameters

PARAMETER	NAME	DESCRIPTION
60000	<i>E2Ins</i>	Total amount of EEPROM storage.
60001	<i>E2Fre</i>	Amount of available EEPROM storage.
60090	<i>SPEED</i>	Set the microprocessor speed. The higher the speed of the processor, the more power consumption. The default value is 3.69 MHz. Press the TARE key on the 350 IS or SAMPLE ENTER key on the 355 IS to change the value.
60100	<i>-GSE- ~ c1998</i>	Copyright statement.
60101	<i>0350P ~ 01001</i>	Firmware revision code.
60102	<i>02- 10 ~ 1998</i>	Firmware date code.
60200	<i>b sn ~ 10001</i>	Main circuit board serial number.
60201	<i>Audit ~ Trail Euro ~ 00000</i>	OIML (European) audit trail number (see <i>OIML Audit Trail</i> on page 84).
60202	<i>i sn ~ 00000</i>	Model 350/355 serial number.
60203	<i>Audit ~ Trail CAL. ~ 00000</i>	Calibration audit trail number (see <i>Calibration Audit Trail</i> on page 84).
60204	<i>Audit ~ Trail Setup ~ 00000</i>	Setup audit trail number (see <i>Setup Audit Trail</i> on page 84).
61100	<i>Load ~ Cell 0.00000</i>	Current mV/V output of the load cell.
61101	<i>Cal ~ Factr 1.00000</i>	Calibration factor for the load cell.
61102	<i>Rezro ~ Load 0.00000</i>	Amount of weight (in default units) zeroed through use of the ZERO key.
61103	<i>Zrtrc ~ Load 0.00000</i>	Amount of weight (in default units) zeroed by the zero track feature since ZERO was last pressed.
61104	<i>CZero ~ 0P</i>	Coarse zero calculated during calibration.
61105	<i>Fine ~ Zero 1738</i>	Fine zero calculated during calibration.
61106	<i>CGain ~ 50</i>	Coarse gain calculated during calibration.
61107	<i>Fine ~ Gain 1.00000</i>	Fine gain calculated during calibration.
61110 ↓ 61112	<i>Zero ~ Adj25 73741</i> ↓ <i>Zero ~ Ad100 -21813</i>	A/D compensation for coarse zero.

PARAMETER	NAME	DESCRIPTION
61117 ↓ 61120	<i>AiN1 ~ NrOff</i> -11035 ↓ <i>AiN8 ~ NrOff</i> -14800	A/D non-ratio-metric offset compensation.
61121	<i>Vref ~ NrOff</i> -12739	A/D reference voltage compensation.
61122	Alt~E=8	Alt E=8 when the 8 volt excitation module is installed or Alt E=5 when 8 volt excitation module is not present.
61200	10oFF	Analog option 0 – 10V Zero offset value.
61201	10Gn	Analog option 0 – 10V Full scale gain value.
61202	0oFF	Analog option 0 – 20mA Zero offset value.
61203	0Gn	Analog option 0 – 20mA Full scale gain value.
61204	4oFF	Analog option 4 – 20mA Zero offset value.
61205	4Gn	Analog option 4 – 20mA Full scale gain value.
61206	Srln	Analog option board serial number.
62000	<i>Dsply ~ Test</i> 8.8.8.8.8.8.	Display test. Press  or  to illuminate all segments. Continue pressing  or  to cycle through various patterns.
62001	<i>Spt 1 ~ Disbl</i>	Allows setpoint status to be changed by pressing  or  while viewing this parameter. Requires that setup was entered using the access code.
62002	<i>Spt 2 ~ Disbl</i>	
62003	<i>Spt 3 ~ Disbl</i>	
62020	<i>AdAnl</i>	Displays the voltage level on the analog voltage used by the A/D converter.
62021	<i>AdbAt</i>	Displays the voltage level on the battery when battery powered. Will show 0 if AC powered.
64000	<i>Send ~ Setup</i>	Transmits all setup information out the communication port.
64100	<i>LnCnt ~ 0</i>	Received setup line count.
64101	<i>ErCnt ~ 0</i>	Received setup error count.
64102	<i>IstEr ~ None!</i>	Parameter of the first setup receive error.
65001	<i>Deflt ~ All</i>	Default All. Sets all parameters to factory default settings. Press  or  to initiate default.
65002	<i>Deflt ~ -CAL</i>	Same as above, except calibration is retained.

A/D Calibration Procedure

The Model 350/355 IS Analog-to-Digital Converter (A/D) is calibrated at the factory to ensure a stable, linear response to the load cell signal. This calibration procedure calculates critical values that are permanently stored in parameters P61110 – P61121. The A/D calibration should not be confused with the standard weight calibration. It should never be necessary to recalibrate the A/D. However, if the values stored at parameters P61110 – P61121 appear to be reset to 0.00000 and/or 1.00000, then A/D recalibration is necessary. Contact GSE Scale Systems or your local authorized GSE distributor for more information on this procedure.

part number 39-10-41432